

INTRODUCTION

1.1 Aim of the Manual of Cancer Services

This revised Manual of Cancer Services is an integral part of the NHS Cancer Plan, Cancer Reform Strategy and modernisation of cancer services. It will support quality assurance of cancer services and enable quality improvement.

The National Cancer Peer Review Programme, which is led by the National Cancer Action Team and includes expert clinical and user representation, provides important information about the quality of cancer services across the country. Between 2004 and 2008 peer reviews of cancer services were carried out in each cancer network in England.

Development of this Manual of Cancer Services 2008 and the continuation of a revised peer review process has been supported by the service and agreed by strategic health authorities following a review of all national programmes in 2007. An independent evaluation of the National Cancer Peer Review Programme also demonstrated strong support for the programme to continue, but recommended that the programme should be modified. A new process was implemented during 2008 but the measures contained within this manual will remain an integral part of the review process.

The manual has not been centrally imposed.

1.2 Background and Context

Substantial progress has been made in cancer in the last decade, particularly since the publication of the NHS Cancer Plan in 2000. However, major challenges remain and in 2007 the Cancer Reform Strategy was published with aims to: save more lives; improve patients' quality of life; reduce inequalities; build for the future; enable cancer care to be delivered in the best place at the right time and achieve maximum value for money.

The Cancer Reform Strategy acknowledges that national guidance will continue to play a vital role as cancer services develop over the next five years. Much of this guidance has been developed by the NICE and predecessor bodies.

Improving Outcomes Guidance (IOG) for cancer services now covers the vast majority of all cancers. Implementation of this guidance, which involves the establishment of multidisciplinary teams and reconfiguration of some complex services, is now well advanced for many cancers and is expected to be completed for less common cancers by 2010 as outlined in the Cancer Reform Strategy.

The revised manual has therefore been drawn up to incorporate the recommendations contained within such guidance including the new guidelines published by NICE. It identifies the characteristics of service that are likely to have a significant impact on health outcomes. It is intended that those characteristics should help those involved in planning, commissioning, organising, and providing cancer services to identify gaps in provision and check the appropriateness and quality of existing services. The measures provide a ready specification for the commissioning of cancer services within a given locality.

Changes have also been made as a result of feedback from the use of measures in the manual published in 2004 and following the most recent independent evaluation of peer review published in December 2007.

There has been a clear commitment to the establishment of an active and positive relationship with the Healthcare Commission and information gathered from the National Cancer Peer Review Programme has been shared with the commission. The Care Quality Commission will play an important role in assessing the quality of cancer; peer review continues to be committed to working in partnership with that organisation to support continued improvement in cancer services.

1.3 Measures within the National Cancer Peer Review Manual

At present peer review focuses largely on measures of structure and process. Over time, as reliable measures of outcome become available, there will be a shift in emphasis.

To date the measures have been confined to adult cancer services, except where they relate incidentally to children, for example a radiotherapy department would normally treat adults and children. However, measures are currently being developed that specifically address the provision of services for children and young adults with cancer.

The development of cancer measures is an ongoing process in order to:

- reflect new NICE guidance and revisions to existing NICE guidance;
- allow greater influence by users of cancer services and their carers;
- take account of possible modifications to measures following peer review visits;
- ensure the scope of measures encompasses the broader implementation of the Cancer Reform Strategy, including actions to support the world class commissioning of cancer services.

1.4 Reviewing the Measures

The National Cancer Peer Review Programme aims to improve care for people with cancer and their families by:

- ensuring services are as safe as possible;
- improving the quality and effectiveness of care;
- improving the patient and carer experience;
- undertaking independent, fair reviews of services;
- providing development and learning for all involved;
- encouraging the dissemination of good practice.

The benefits of peer review have been found to include the following:

- provision of disease specific information across the country together with information about individual teams which has been externally validated;
- provision of a catalyst for change and service improvement;
- identification and resolution of immediate risks to patients and / or staff;
- engagement of a substantial number of front line clinicians in reviews;
- rapid sharing of learning between clinicians, as well as a better understanding of the key recommendations in the NICE guidance.

The new National Cancer Peer Review Programme has taken into account comments received during the 2004 – 2008 review programme and will focus more on annual self assessment, completed by individual teams and services and signed off by the relevant provider CEO and by the cancer network. Targeted and a random sample of self assessments will be externally verified by zonal teams on an annual basis. Some external visits will continue but this will become the exception rather than the rule once a team has demonstrated a high level of compliance with the measures. Peer review data will continue to be published to assist commissioners and promote transparency on service performance.

The relationship between the NICE Improving Outcomes Guidance and the quality measures within the Manual for Cancer Services is explained in more detail in [appendix A](#).

Appendix A

Interpretation of the National Manual of Cancer Services 2008

1.1 Guidance Compared to Cancer Measures

The NICE IOG is exactly what it says – guidance in general and indeed is excellent for this purpose. Guidance involves giving advice and recommendations on how things should be done now, in the future and sometimes on how things should have been done for sometime already. It may involve describing in effect the “perfect” service, using phrases like “the best possible”, “to all patients at all times”, etc. It may involve all-inclusive and far-ranging objectives and aspirations involving many agencies in long, interlinked chains of events and tasks which all have to be fulfilled before the desired outcome of the guidance is achieved. A particular person’s accountability for each task is often not stated.

It may use influential and important ideas and models, which are however complex or not precisely definable, such as “network-wide patient care pathways” or “culturally-sensitive information”. It always contains useful and necessary value judgements which use words like “sufficient”, “appropriate”, “robust” and “comprehensive”, but it often has to leave unanswered the key question – what exactly is it which makes the issue under examination “sufficient”, “appropriate”, “robust” and “comprehensive” or not? It uses concepts which, although crucial, may not be measurable. It ranges widely from things which everybody gets right as a matter of course already through to principles which, if taken literally, nobody would comply with ever.

All these features, although they may sound unhelpful as described above, are present in all guidance documents and are part of the necessary and accepted style of guidance writing. Without this underlying type of mindset guidance would not inspire, lead, motivate or guide and would probably be almost unreadable. The Manual of Cancer Services has to take a different approach. It is written for and only for the specific purpose of being used to assess a service against it, to aid self assessment and team development (a) by a peer review visit; (b) on a specific occasion; (c) a visit which has to be fair compared to visits to other services elsewhere and (d) to past and future visits to the same service. Therefore, the measures have to:

- be objective – with as little room as possible for arguments between assessors and assessed; and between different teams of assessors;
- be measurable – and at least capable of definitely being complied with or not;
- be specific – not addressing several issues at once or long, linked chains of tasks all being done by different agencies;
- be verifiable – by evidence produced for the visit;
- state who exactly is responsible for what – or nobody may take responsibility for anything;
- sometimes deal with the implications of the guidance – which may not have been explicitly stated but which are essential for anything to actually happen;
- be discriminating – it’s no use spending time and money on assessing something which everybody gets right already;
- be achievable – it’s no use committing everybody to permanent and automatic failure because of the way something is worded;
- be clear and unambiguous – the words will be taken to mean exactly what they appear to say, and therefore they have to say exactly what we mean and nothing else;
- pick out and address the most important issues – the peer review process is limited in its scope;
- be developmental – encourage continuous quality improvement and not produce destructive competition or a sense of failure;
- be sensibly and fairly related to previous standards – in order to be developmental – not just arbitrarily moving the goal posts.

All this results in the rather esoteric style of the manual. Please judge the measures on their merits in the light of the above and not in comparison to the guidance.

1.2 “The Responsibility for Assessment Purposes”

This refers to the fact that someone, or some group, is always held nominally responsible for compliance with each one of the quality measures. This has to be specified or, in terms of organising the peer review and collecting the results, it would be unclear who was being held as compliant or non-compliant or who the results could be attributed to. Where it is unclear who has responsibility there tends to be inertia. This attribution of responsibility does not necessarily commit a given person to actually carrying out a given task – this can be delegated according to local discretion, unless it is clear that a given task really is limited to a certain group.

1.3 “Agreement”

Where agreement to guidelines, policies et cetera is required, this should be stated clearly on the cover sheet of the three key documents including date and version. Similarly, evidence of guidelines, policies etc requires written evidence unless otherwise specified. The agreement by a person representing a group or team (chair or lead etc) implies that their agreement is not personal but that they are representing the consensus opinion of that group.

1.4 Confirmation of Compliance

Compliance against certain measures will be the subject of spot checks or further enquires by peer reviewers when a peer review visit is undertaken. When self assessing against these measures a statement of confirmation of compliance contained within the relevant key evidence document will be sufficient.

1.5 “Quality” Aspects of Cancer Service Delivery

Many of the measures expect that policies, procedures, job descriptions and other documents will be in place. In reviewing compliance with the measures (for instance measure met or not) during validation, verification and visits, reviewers will look only for the presence of such documents, unless aspects of the content are specified in the wording of the measure. Where some aspect of the content is specified then this will be taken into account in determining compliance. As part of the improvement of cancer services, reviewers may comment on the content of documents and agreements but this will not affect the determination of compliance.

Work is ongoing to enable us to subject more of the “quality” aspects of cancer service delivery to objective measures for future rounds of peer review.

Many reviewers have a legitimate and valuable contribution to make by way of comments on areas which are a matter of opinion rather than fact or authoritative and evidence based standards. This recognises the qualitative as well as quantitative approach to reviews. This contribution can be made by way of a textual report in addition to the objective recording of compliance against the measures. This report is separate from the review against the measures and is inevitably more subjective and open to debate. However, there are many ways in which it can add to the overall picture gained from the peer review.

Topic 4 covers cancer registries.

Topic 5 covers cancer research networks.

Topic 6 covers primary care trusts.

Topic 7 covers children's cancer.

Some themes, such as service improvement, patient centred care, general supportive and palliative care and data collection are addressed at various places within the Manual of Cancer Services.

Each network will be made up of several localities and several NSSGs / cross cutting groups, each with multiple MDTs and services. These MDTs and services will each need to demonstrate compliance with the relevant National Cancer Quality Measures. A network overview will be developed by bringing together the findings relating to individual MDTs and services as well as those concerning network organisation and structures.

Manual of Cancer Services On-line

To assist cancer networks to navigate round the measures - and to help individuals focus on the measures of interest to them – an on-line version of the Manual of Cancer Services has been developed. The on-line version allows individuals to identify and extract measures by tumour site, organisation type and subject area in a variety of formats.

The on-line manual can be accessed from the CQuINS web site at <http://www.cquins.nhs.uk>.

Scope and Format of the Measures

The above considerations have led to the way the children and young adult's cancer measures have been formulated, which in turn gives rise to the way the infrastructure will be peer reviewed, the way results will be recorded and collated and to whom they will be attributed.

The functional unit for children's cancer services, the CCN, consists of a Principal Treatment Centre (PTC) and usually one or more referring Paediatric Oncology Shared Care Units (POSCUs) and their respective catchment areas. Because as outlined above this may well encompass more than one cancer network, the way the results of a peer review of a CCN relate to the peer reviews of any cancer networks it encompasses needs to be considered.

The measures are formatted such that the peer review will be of the CCN as a distinct entity, not primarily a review of the corresponding parts of the cancer networks involved. However, there are requirements for the leadership and governance of the CCN to be integrated with that of the corresponding cancer networks. Thus the PTC will be associated with a host cancer network and be declared as a part of one of its localities. The POSCUs will also each be part of a named locality of a cancer network in which they are sited.

It will be possible, therefore, to associate the relevant parts of the CCN's review outcome with the corresponding cancer network through the CQuINS results database.

The functional unit for teenage and young adult's cancer services, the TYACN, consists of a Teenage and Young Adults Cancer Unit (TYACU) and the structures and services it relates to for referral and shared care. These structures may potentially include children's MDTs and local and specialist adult cancer service MDTs. The way its catchment relates to CCNs and cancer networks may vary according to local arrangements. The measures are formatted so that the peer review will be primarily of the TYACN as a distinct entity, with the ability to relate the outcomes to the relevant cancer networks as outlined above. The measures for the peer review of TYACUs will be published separately.

Although the CYPIOG covers all of the cancer services for this age range it is not practical to duplicate all the components of the adult cancer peer review for these services. Certain aspects will either be omitted or dealt with more simply. Measure for palliative and supportive care services for children, as well as for young adults and adults, will be produced as part of a forthcoming revision of palliative and supportive care services in general.

Radiotherapy for children with cancer is given as part of the general work of radiotherapy departments. There are no radiotherapy departments devoted exclusively to the treatment of children. Thus, the general quality measures for a radiotherapy department cover its treatment of children as well as all other patients. This is dealt with comprehensively in the Radiotherapy Measures, in the Manual for Cancer Services, topic 3T. A small number of measures which relate only to *Children's* radiotherapy are included in this topic, children's cancer measures topic 7, rather than topic 3T. (See also Introduction to the Radiotherapy Measures, topic 3T, Manual for Cancer Services.)

The MDTs for the children's age group are not primarily organised on a site specific basis. They are organised somewhat differently. The measures require a minimum range of MDTs to be put forward for review. These MDTs and the criteria they are required to fulfil are as follows:

- the PTC diagnostic and treatment MDT(s); there are requirements to be fulfilled for the configuration of these teams in the PTC; there should only be one such team for its particular declared range of tumour types for the PTC;
- the PTC Late Effects MDT of which there should be only one for the PTC;
- the POSCU MDT of which there should only be one in a given POSCU.

Regarding the required components of a POSCU, the recommendations of the CYPIOG have been supplemented by work produced by the Shared Care Working Party. Three levels of care have been defined for a POSCU in terms of what types of clinical activity may be undertaken with the corresponding requirements for staff and facilities. The measures for a given POSCU will be

determined therefore by the level (1, 2 or 3) which is agreed for that POSCU between it, the PTC and the specialist commissioners.

The development of each CCN and TYACN will be monitored in terms of reaching the milestones outlined in the "proposals for implementation" document, by the relevant specialist commissioners group (SCG) who will also eventually monitor the implementation of any remedial actions recommended from the outcome of peer review.

Building the Children's Cancer Network

This exercise was preceded by a baseline assessment of services by SCGs.

Outside (not subject to) Peer Review – Distribution of CCNs

SCGs agree with strategic health authorities, trusts and cancer networks, the location of PTCs and the pattern of association of individual cancer networks to form the CCNs and therefore the proposed catchment for each given PTC.

Subject to Milestones for the Implementation Proposals, Cancer Measures and Peer Review – Development of Services within the CCN

Phase 1:

- i) establishment of the CCN co-ordinating group; meeting with required membership;
- ii) agreeing the location and component hospital(s) and services of the PTC;
- iii) agreeing, if applicable, any referral arrangements outside the CCN; (for illustration – primary intra-ocular tumours, primary bone tumours, brain and CNS tumours, thoracic surgery, complex pelvic surgery, soluble radioisotope therapy);
- iv) agreeing the location, component hospitals and services and the functioning levels of any POSCUs.

Phase 2:

- i) establishing the PTC MDTs (diagnostic and treatment, and late effects); meeting with required membership;
- ii) establishing the POSCU MDTs; meeting with required membership;
- iii) agreeing CCN-wide protocols for referral, treatment and follow up, between PTC MDTs, POSCUs, the teenage and young adults MDT and site specialised MDTs;
- iv) achieving the minimum core staffing and facilities of the PTC;
- v) achieving the minimum core staffing and facilities of the POSCUs;
- vi) MDTs receiving referrals according to protocols; any consequent workload transfers begin.

Reviewing the Children's Cancer Network

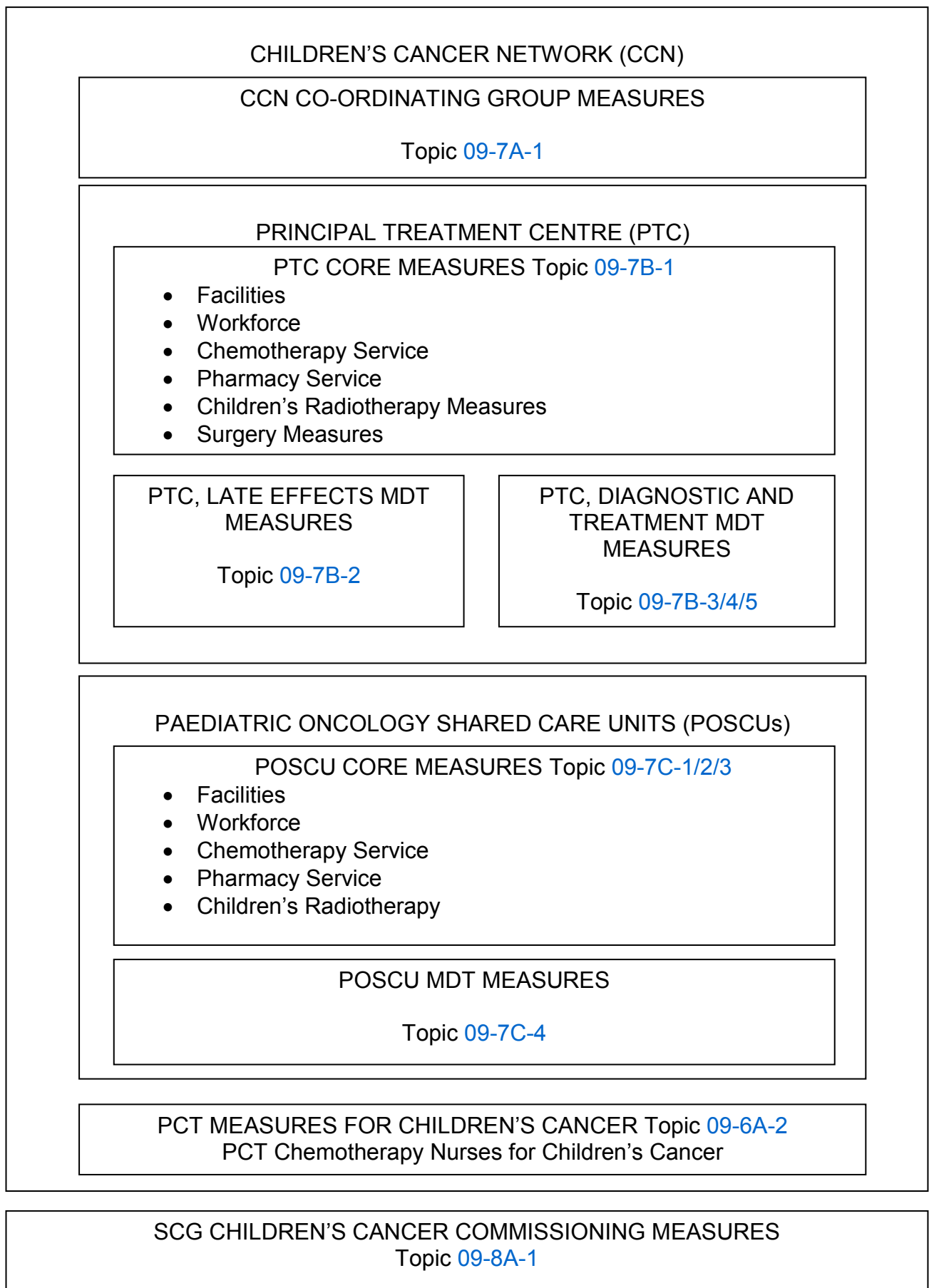

Reviewing the Children's Cancer Network

The Peer Review is carried out under the following sections:

1. [09-7A-1](#) The Children's Cancer Network

Establishing the CCN co-ordinating group; declaring the location and constituent hospitals of the PTC; agreeing the location, constituent hospitals and functioning levels of the POSCUs; agreeing the referral and management protocols between POSCUs, PTC MDTs, teenage and young adult's MDTs, site specialised MDTs and late effects MDTs. For the purposes of the measures and peer review these are considered to be the responsibility of the chair of the CCN and are reviewed under topic [09-7A-1](#) the children's cancer network, the compliance counting towards the review of the CCN co-ordinating group.

2. [09-7B-1](#) The PTC Core Measures

The core staff, leadership, facilities, chemotherapy service, children's radiotherapy measures and surgery measures. For the purpose of the measures and peer review these are the responsibility of the clinical lead of the PTC and are reviewed under topic [09-7B-1](#) the PTC, the compliance counting towards the review of the PTC.

3. [09-7B-2](#) The PTC Late Effects MDT

Membership and functions. For the purpose of measures and peer review the responsibility for this lies with the lead clinician of the MDT and is reviewed under topic [09-7B-2](#) the PTC late effects MDT, compliance counting towards the peer review of the MDT. The measures will be applied separately to each diagnostic and treatment MDT in the PTC.

4. [09-7B-3/4/5](#) The PTC Diagnostic and Treatment MDT(s)

Membership and functions. For the purpose of the measures and peer review the responsibility for this is that of the lead clinician of the MDT and it is reviewed under topic [09-7B-3/4/5](#) the PTC diagnostic and treatment MDT(s), compliance counting towards the peer review of the MDT.

5. [09-7C-1](#) The POSCU Level 1 Core Measures

6. [09-7C-2](#) The POSCU Level 2 Core Measures

7. [09-7C-3](#) The POSCU Level 3 Core Measures

The core staff, leadership, facilities, chemotherapy service and (where applicable) children's radiotherapy measure. Measures are applied differently for each of the three levels of POSCU. For the purpose of the measures and peer review, the responsibility for this lies with the clinical lead of the POSCU and it is reviewed under topic [09-7C-1/2/3](#) the POSCU core measures, compliance counting towards the review of the POSCU. There is a separate review for each POSCU in the CCN.

8. [09-7C-4](#) The POSCU MDT

Membership and functions. For the purpose of the measures and peer review, the responsibility for this lies with the lead clinician of the MDT and is reviewed under topic [09-7C-4](#) of the measures, compliance counting towards the review of the MDT.

9. [09-6A-2](#) PCT Children's Cancer Measures

For the purpose of the measures and peer review, the responsibility for this lies with the cancer clinical lead of the PCT and is reviewed under topic [09-6A-2](#), compliance counting towards the peer review of the PCT.

10. [09-8A-1](#) The SCG Children's Cancer Commissioning Measures

For the purpose of the measures and peer review, the responsibility for this lies with the nominated person from the SCG, compliance counting towards the peer review of the SCG.

Reviewing the Teenage and Young Adult's Network

This will be reviewed separately against a separately published set of measures.

Nomenclature

For the purpose of the milestones, cancer measures and peer review, the following terms are used:

- One of the currently existing networks for cancer services as defined in and reviewed against the Manual of Cancer Services – “The Cancer Network”.
- A commissioned network of services for children's cancer – “The Children's Cancer Network, CCN”.
- A commissioned network of services for teenage and young adult's cancer – “The Teenage and Young Adult's Cancer Network, TYACN”.
- A collection of central services and facilities for children's cancer as set out in the measures – “The Principal Treatment Centre, PTC (Children)”.
- A collection of central services and facilities as set out in the measures, offering an age appropriate environment for the treatment and support of teenagers and young adults with cancer – “The Principal Treatment Centre, PTC (Teenage and Young Adults)”.
- A collection of services sharing care for children's cancer with and under the guidance of a PTC – “The Paediatric Oncology Shared Care Unit, POSCU”.
- A collection of services sharing care for young adult's cancer with and under the guidance of a PTC – “The Teenage and Young Adults Shared Care Unit”.
- The terminology used for the delivery of chemotherapy is that set out in the Introduction to the Chemotherapy Measures, Manual of Cancer Services.

Shared Care Levels for POSCUs

POSCU Level 1 Services

- inpatient supportive care including care of children with febrile neutropœnia
- outpatient supportive care
- outpatient follow up
- outpatient oral chemotherapy
- outpatient IV bolus chemotherapy
- exclusions - day care infusional chemotherapy, inpatient chemotherapy and all exclusions listed in level 3.

Allowable options from the above:

1. all the above services
2. opt out of outpatient IV bolus chemotherapy only
3. opt out of outpatient IV bolus chemotherapy and inpatient supportive care including care of children with febrile neutropœnia
4. opt out of all chemotherapy and inpatient supportive care including care of children with febrile neutropœnia

NB: The implication of this is that any service that is providing outpatient IV bolus chemotherapy should also provide care of children with febrile neutropœnia.

POSCU Level 2 Services

- as for level 1 and in addition day care infusional chemotherapy
- exclusions - inpatient chemotherapy and all exclusions listed in level 3.

POSCU Level 3 Services

- as for level 2 and in addition inpatient 24-hour chemotherapy
- an intrathecal chemotherapy service in a POSCU is an option for level 3 (only) providing the following are fulfilled:
 1. compliance with HSC 2003-010, as verified by a satisfactory peer review against the ITC measures (Manual for Cancer Services 2004, section [3C-3](#), or any measures which supersede it);
 2. paediatric anaesthetic service on site;
 3. agreement by CCNCG.

Level 3 Exclusions, for instance services which should only be offered in a PTC

1. final diagnosis and determination of treatment plan;
2. chemotherapy regimens or other procedures which would be rendered unacceptably hazardous or have their effectiveness reduced by reason of the limits of infrastructure or experience available at any of the POSCUs; these regimens and/or procedures should be specified at any one time for the CCN by the CCNCG;
3. stem cell transplantation;
4. recruitment to, and co-ordination of, phase I, II and III clinical trials;
5. radical radiotherapy.

Notes on Application of the Levels

The care “level” of a POSCU determines the highest level of services which it should offer. It may (and probably will) offer services at levels lower than its agreed level. If the POSCU is agreed as being allowed to offer services at a given level it is then required to have at least the minimum supporting infrastructure (staff and facilities) corresponding to that level. The POSCU is required to put its infrastructure forward against the corresponding infrastructure measures in topic [09-7C-1/2/3](#) for detailed peer review. Any given measure for a POSCU applies to all levels of POSCU unless otherwise specified.

The level 3 exclusions define a set of services which should only be offered by a PTC but a given PTC need not offer all of them. Also, some “PTC – only” services require that a PTC fulfils certain additional conditions specific to that service. These and the infrastructure requirements for PTCs in general are dealt with in the measures in topic [09-7B-1](#), against which the PTC should be reviewed. It is expected that a PTC should be offering POSCU levels 1 to 3 care (mostly to its own secondary catchment area) in addition to the PTC – only services.

The Children’s Cancer Network Co-ordinating Group

The nature of this group as specified in the measures (covering its establishment, membership, terms of reference and essential functions), has been influenced by a number of issues. These are mostly issues over which the peer review of children’s cancer services differs from that of adults and are as follows:

1. The CYPIOG and the subsequent debates surrounding its implementation have attributed the responsibility for deciding protocols and policies for the CCN in various ways. Sometimes it has been considered the responsibility of ‘the PTC’; sometimes there has been a requirement for dialogue and agreement across several components of the CCN; and sometimes no clear agent has been identified.

‘The PTC’ is actually a complex collection of people, facilities and activities, which can’t in itself ‘agree’ or ‘sign up’ to anything in reality. This function needs to be embodied in a defined group of people, ideally with a chair who can be called upon to voice and authorise their consensus decisions.

2. In practice, protocols and policies for the CCN need CCN-wide ownership for success, rather than being imposed by an authoritarian PTC.
3. The CYPIOG and the surrounding debates have made it clear that commissioners should be directly involved in determining some policies (for example the siting and care levels of the POSCUs).
4. Because of the relatively limited extent of children's cancer services, compared to the vastly greater size of adult cancer services, we should not try and reproduce the complexity of adult cancer networks in the measures for, and peer review of, children's cancer networks. Thus, there are no children's measures for the various 'cross cutting' groups and 'networks site specific groups' unlike the rest of the manual, which applies to adult services.

Taking all these issues into consideration, the responsibility for agreeing protocols and policies for the CCN, and for some of the key functions of the other groups mentioned above, has been attributed in the children's cancer measures to the CCNCG. This is a group whose membership recognises that the PTC is the direct influence in the CCN, but which is balanced by representation from the other providers in the CCN and from commissioners in order to increase the breadth of ownership and the degree of objectivity of its decisions.

See [figure A](#) for an illustration of how the components of the CCN interrelate and [figure B](#) for an illustration of how CCNs, SCGs and cancer network interrelate.

Fig A. Service Relationships within the Children's Cancer Network

Note to fig A. This is not a comprehensive description of all the activities concerned. It is a visual aid to the configuration of the CCN

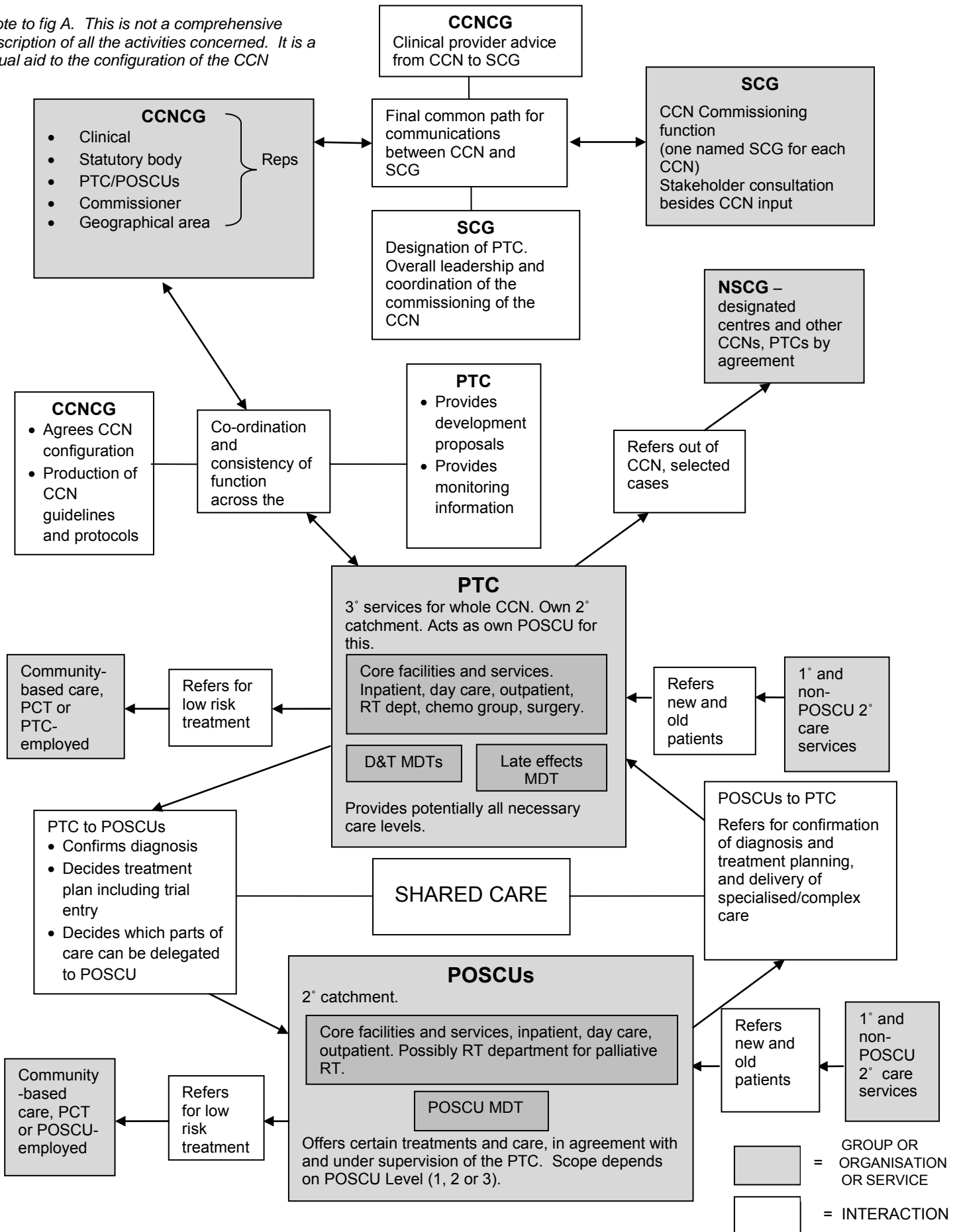
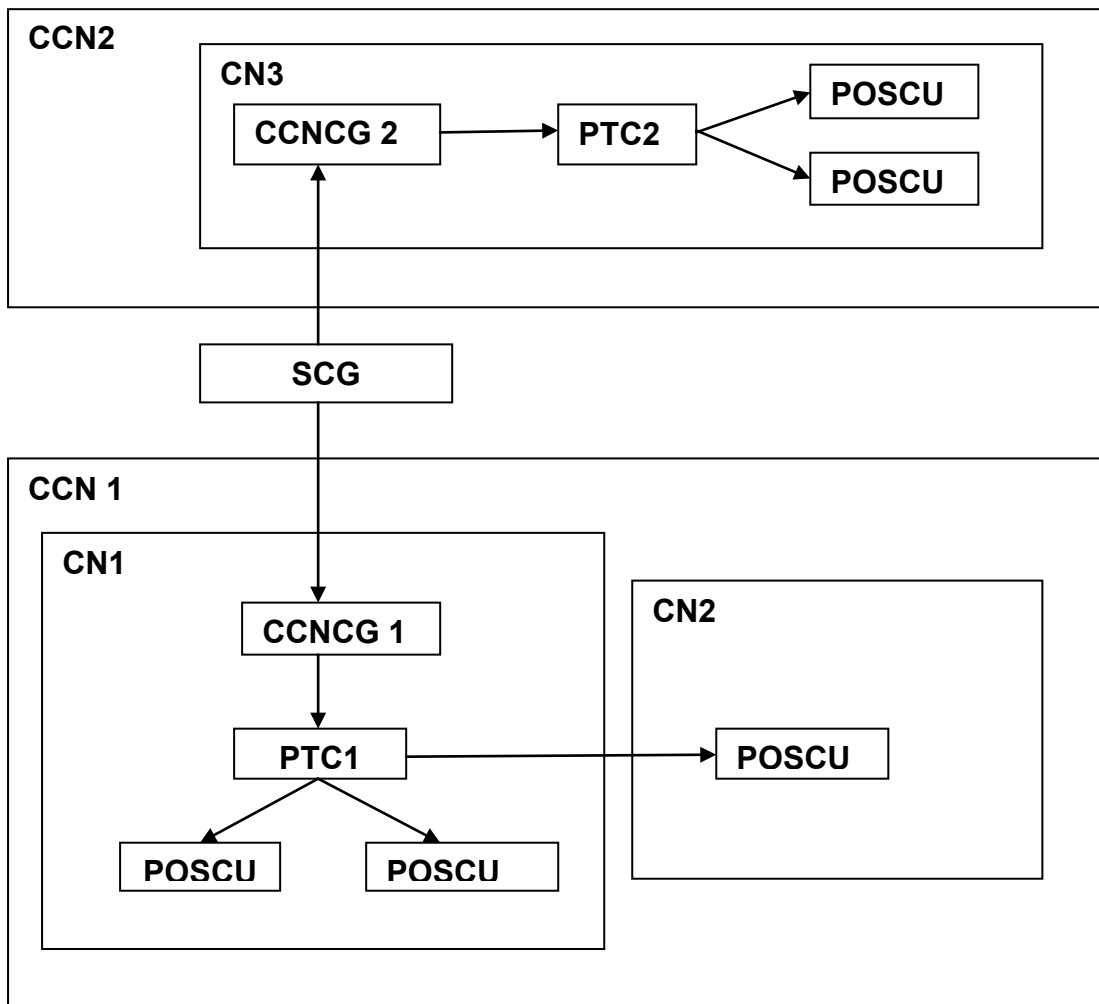

Figure B. An example of how CCNs, CNs (adult cancer networks) and SCGs may not be co-terminous



Training and Staffing Level for Specialist Nurses

Introduction

The CCNCG should agree a nurse training programme in oncology skills and chemotherapy administration covering certain core competencies specified below (internal training). The CCN may or may not choose to extend this programme to provide more comprehensive training, but it is not primarily intended, by these measures, to initiate new, university accredited courses in paediatric oncology. At the time of writing there are currently a number of courses open to candidates nationally providing training for paediatric oncology skills for nurses, which are university-accredited for 20 credits at first degree level. Where additional training beyond the internal training is required for compliance with these measures it is intended that the CCN should use these currently existing courses (external training).

There should be named and experienced paediatric oncology nurses for each CCN who should be responsible for the internal training and assessing the core competencies of staff. The CCNCG may choose to share the provision of such an internal training programme and the employment of trainers and assessors with one or more CCNs.

Specialist Nurse Roles dealt with in the Measures

1. oncology ward nurse, delivering children's cancer care and administering chemotherapy;
2. oncology ward nurse, delivering children's cancer care but not administering chemotherapy;
3. day care facility nurse, delivering children's cancer care and administering chemotherapy;
4. day care facility nurse, delivering children's cancer care but not administering chemotherapy;
5. nurse administering only CCN-agreed low risk chemotherapy (normally working in the POSCU or the community setting);
6. MDT nurse specialist and core MDT member;
7. lead nurses (lead nurses could, in principle, occupy the role of core MDT nurse member).

Types of Specialist Nurse Training dealt with in the Measures

External, university-accredited to 20 credits at first degree level, national courses:

- type 1 - chemotherapy administration and oncology skills for paediatric oncology.
Note: 20 credits may not be achievable in some single module courses; reviewers should exercise judgement over this.

Internal, CCN-agreed, RCN competency-based:

- type 2 'Full' – chemotherapy administration and oncology skills;
- type 3 'Foundation' – oncology skills for nurses not administering chemotherapy;
- type 4 'Low Risk' – chemotherapy competencies focused only on administration of a CCN-agreed limited list of low-risk regimens.

Relationship Between Types of Training/Exemption Arrangements

External is intended to be at greater depth than internal, to provide exemption from 'full internal' training and also from foundation and low risk training.

Full internal encompasses and provides exemption from foundation and low risk training.

Foundation and low risk are tailored to their specific nurse roles and of themselves provide no exemption from another complete training type. However, nurses should be able to move between roles within the internal training programme by acquiring, and being assessed for, just those additional competencies which would then complete the required training type.

Exemption from external training (and therefore from all types of internal training) may be conferred as follows:

A nurse who already holds other training qualifications which are of equal or greater academic or professional standing to that specified as 'external training' above and which may be considered applicable to paediatric oncology, may be considered compliant with the measures and should discuss this with the reviewers. This includes qualifications which pre-date the 'credits' system.

Examples which would automatically comply include:

- ENB 240
- ENB237, undertaken by a RN child
- ENBR62

Exemptions specifically for training in chemotherapy administration for entry on to the authorised list other than those related to external and internal training are as follows:

- i) staff who have been assessed for competency by a trainer qualified to the equivalent of that in measure [09-7B-146](#) during the year prior to publication of the measures;
- ii) staff who have two or more years experience of chemotherapy administration prior to the publication of the measures.

Competencies for Internal Training

Full Internal Training

The competencies should include at least those specified in “Competencies: an education and training competency framework for administering medicines intravenously to children and young people”, Royal College of Nursing; publication code 003 005 Domains 1-5 and “Competencies: an integrated competency framework for training programmes in the safe administration of chemotherapy to children and young people”, Royal College of Nursing; publication code 002 501.
(Note: these documents are currently under review).

Low Risk Chemotherapy Training

All of the domains 1-5 above should be considered but it is necessary to include only those competencies which the CCNCG agrees are relevant to the regimens on the CCN low risk list of regimens.

Foundation

The competencies should cover at least the following:

- management of central venous access devices;
- care of a child who is febrile and neutropenic;
- administration of blood products.

Note: The RCN competency document may be used for further guidance.

Nurse Numbers and Training by Location and Setting

The measures specify certain minimum requirements for the types of training and numbers of trained nurses, which vary according to whether the locality is the PTC or the different levels of POSCU and also whether the setting is inpatient, day care or community based care.

The full recommendations of the RCN for nurse numbers can only be implemented at a PTC as the numbers of staff and patients in POSCUs are too small for the recommendations to be applicable. The POSCU requirements have therefore been simplified. There are also measures for core nurse MDT members and for lead nurses. For community-based nurses, the responsibility for their training and authorisation to administer chemotherapy, from the point of view of the peer review, lies with the PCT for PCT-employed nurses and with the PTC or POSCU for hospital-employed nurses. Their actual training and assessment is likely to be provided by PTC/hospital based staff rather than by staff of the PCT.

Figures 1 to 4 Nursing Service Models, for Different Settings.

Figure 1

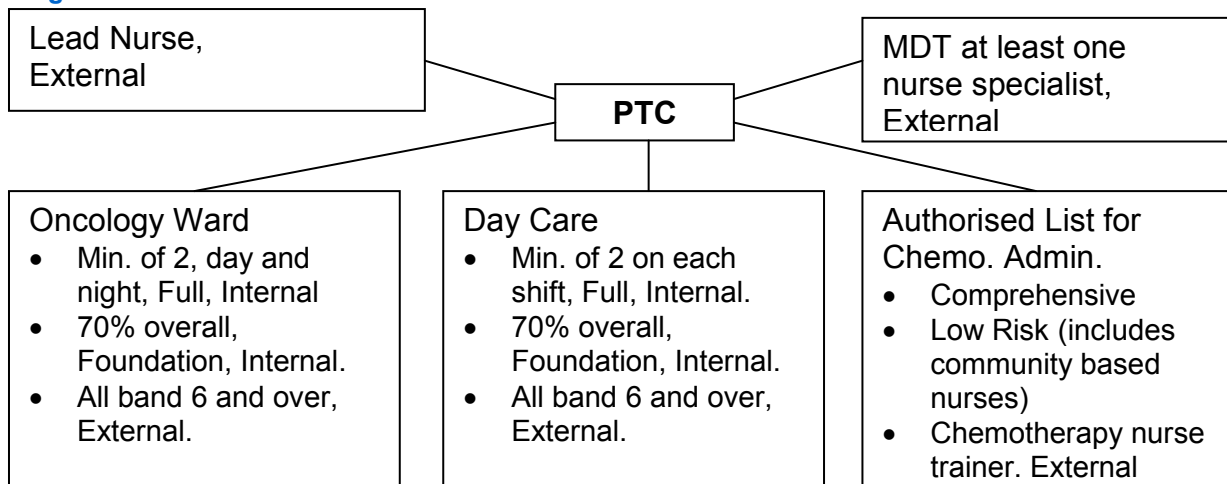

Figure 2

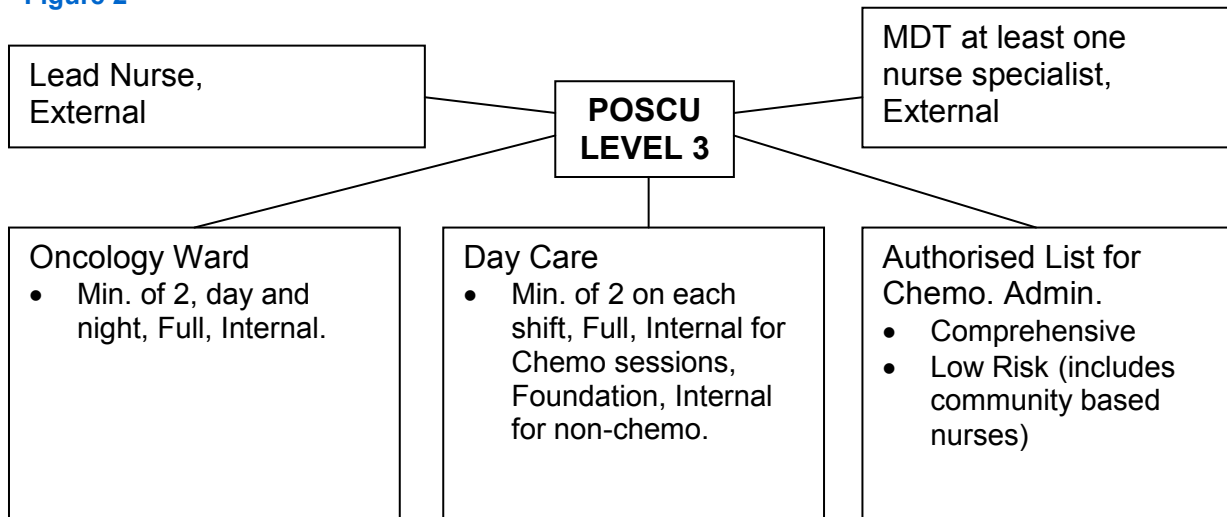

Figure 3

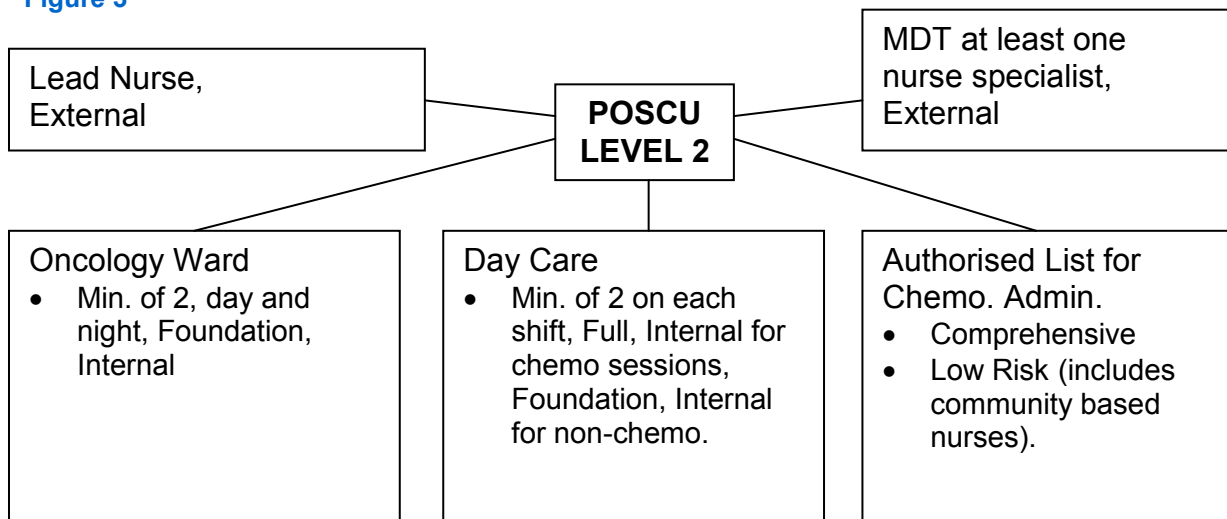
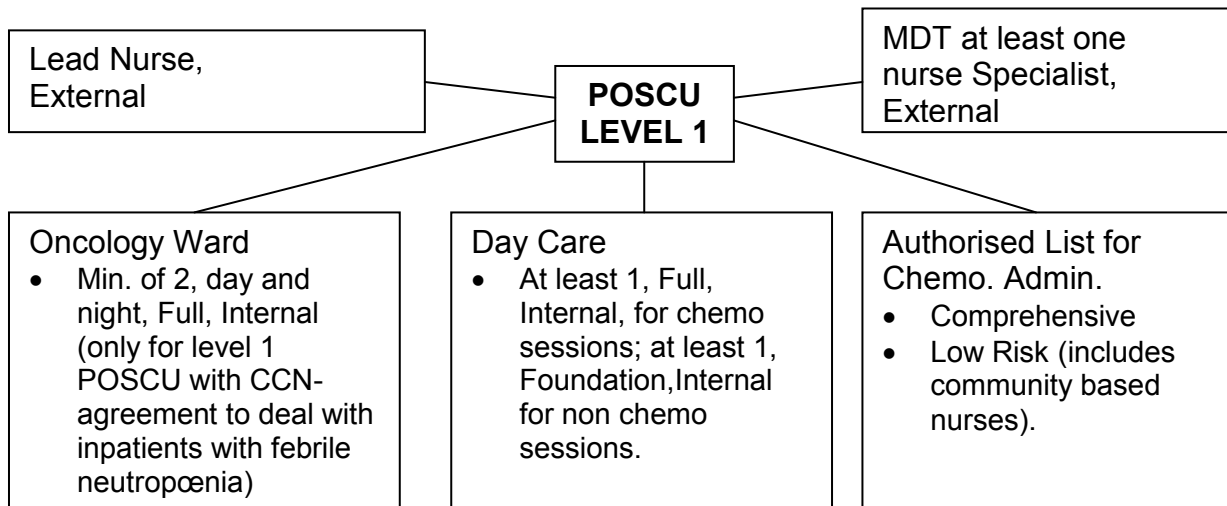

Figure 4



Note to figs 1-4. The role of lead nurse and that of an MDT nurse specialist could be undertaken by the same person, fulfilling the relevant requirements for each role, according to the measures.

It takes time to implement this, so the significance of a service's failure to have staff with CCN based training or, where relevant, university-accredited training increases with the run up time available to them before the service's peer review visit. Lack of compliance should be a matter for discussion between the zonal peer review co-ordinating team and the relevant SHA.

List of Abbreviations

CCLG	Children's Cancer and Leukaemia Group
CCN	Children's Cancer Network
CCNCG	Children's Cancer Network Co-ordinating Group
CE	Chief Executive
D and T MDT	Diagnostic and Treatment Multidisciplinary Team
DCC	Direct clinical care
ENB	English Nursing Board (now disbanded)
EQA	External quality assurance
HDU	High dependency unit
ITC	Intrathecal chemotherapy
ITU	Intensive therapy unit
MDT	Multidisciplinary team
NSCG	National Specialist Commissioning Group
ODP	Operating department practitioner
PA	Programmed activity
PCT	Primary care trust
POSCU	Paediatric oncology shared care unit
PTC	Principal treatment centre
PTCCG	Principal Treatment Centre Chemotherapy Group
RCN	Royal College of Nursing
RN	Registered nurse
RSCN	Registered sick children's nurse
SCG	Specialist commissioning group
SLA	Service level agreement
ST3	Specialist trainee (level 3)
TYA	Teenage and young adults
TYACN	Teenage and Young Adults Cancer Network
TYACU	Teenage and Young Adults Cancer Unit
WTE	Whole time equivalent

TOPIC 09-7A-1 - THE CHILDREN'S CANCER NETWORK (CCN) AND THE CO-ORDINATING GROUP (CCNCG)

Introduction

The CCN's management and organisation of children's cancer services is the subject of the measures in this section. The results count towards the review of the CCNCG. The introduction to the children's cancer measures should be studied before applying these measures, especially the section on the children's cancer network co-ordinating group. The term CCN means the whole collection of children's cancer services in the children's cancer network. The term CCNCG means the group of people who co-ordinate it's function.

MEASURE DETAILS & DEMONSTRATION OF COMPLIANCE

THE ESTABLISHMENT OF THE CCN CG AND LEADERSHIP OF THE CCN (Measures [09-7A-101](#) to [09-7A-107](#))

The responsibility for review purposes for this measure lies with the acute trust CEs, PCTs and SCGs involved in the CCN. For convenience a single acute trust CE, a single PCT CE and a single representative of the SCGs with written delegation of authority from the others may agree the measure on behalf of all for demonstration of compliance. This delegation arrangement also applies to measures [09-7A-104](#) to [09-7A-107](#).

The Chair of the CCN

09-7A-101

There should be a single named chair of the CCN.

The minimum time expected to be spent on the role of chair should be specified.

The chair of the CCN should personally agree a description of the role of chair with the CE or CEs of the SCG(s) relevant to the CCN, which fulfils the following:

- it specifies the relationship between the chair of the CCN and the statutory bodies and the relevant SCG(s), in terms of:
 - i) the relative accountabilities of the various parties;
 - ii) the authority delegated to the chair of the CCN and, as a corporate body, the CCNCG;
 - iii) the balance between the advisory and executive role of the chair and, as a corporate body, the CCNCG;
- it specifies a list of responsibilities of the chair of the CCN.

Notes:

This should be a commissioner.

Compliance: The named chair, the specified time and the role description to be agreed by the chair of the network, the SCG CEs and PCT representatives.

Note:

An agreed summary is sufficient provided it shows compliance with the measure.

The responsibility for measure [09-7A-102](#) lies with the chair of the CCN.

THE CCN LEADS (Measures [09-7A-102](#) to [09-7A-106](#))

Introduction

Outline lists of responsibilities are attached for illustration only as appendices to the measures:

- the lead clinicians of the PTC and POSCUs should be doctors at consultant level practising in the field of childhood cancers;
- this applies also to children's cancer leads for cancer networks;
- local arrangements may involve deputy leads and other leads but a single name should be put forward for review for each position specified in the measures.

MEASURE DETAILS & DEMONSTRATION OF COMPLIANCE

Lead Clinician for the PTC

09-7A-102

There should be a single named lead clinician for the PTC.
The lead clinician should have a list of responsibilities of the position.
The time available (expressed in whatever units are used in their contract) for those responsibilities should be specified.

Compliance: The named clinician, the list of responsibilities and specified time agreed by the chair of the CCN.

Lead Nurse for the PTC

09-7A-103

There should be a single named lead nurse for the PTC.
The lead nurse should have an agreed list of responsibilities of the position.
The time available for these responsibilities should be specified.
The lead nurse should have completed the external training requirements for specialist nurses (see Introduction to the Children's Cancer Measures).
The lead nurse of the PTC should be working full time in paediatric oncology; at least 50% of this wte should be spent on responsibilities of lead nurse for the PTC.

Note:

*It is **not** a requirement for the lead nurse to be a core member of any of the PTC MDTs, although the PTC may choose to do this.*

Compliance: The named nurse, the list of responsibilities and specified time agreed by the chair of the CCN.

Lead Clinician for Childhood Cancer in each Cancer Network

09-7A-104

There should be a single named network lead clinician for childhood cancer, in each of the cancer networks covered by the CCN.
The lead should have contracted session(s) and have worked in the cancer network for which they are the lead.
The network lead should have an agreed list of responsibilities of the position.
The time available for these responsibilities should be specified.

Compliance: The named lead, the list of responsibilities and the specified time for each cancer network agreed by the chair of the CCN, the trust and PCT CEs involved in the component cancer network in question.

Notes:

For compliance this measure should be fulfilled for each component cancer network of the CCN. They may or may not act as lead clinicians of a PTC or POSCU as well.

Lead Clinician for each POSCU in the CCN

09-7A-105

There should be a single named lead clinician for each POSCU in the CCN.
The lead should have an agreed list of responsibilities of the position.
The time available for these responsibilities should be specified.

Compliance: The named lead clinician, the list of responsibilities and specified time for each POSCU in the CCN agreed by the chair of the CCN.

Note:

For compliance this measure should be fulfilled for each component POSCU in the CCN.

Lead Nurse for each POSCU in the CCN

09-7A-106

There should be a single named lead nurse for each POSCU in the CCN.
The lead should have an agreed list of responsibilities of the position.
The time available for these responsibilities should be specified.
The responsibilities should include core membership of the POSCU MDT.
The lead nurse should have completed the external training requirements for specialist nurses (see Introduction to the Children's Cancer Measure).

MEASURE DETAILS & DEMONSTRATION OF COMPLIANCE

The lead nurse of a level 3 POSCU should be a nurse working full time in paediatric oncology. (Part of this wte should be specified as being spent on the responsibilities of lead nurse).

The lead nurse of a level 1 and a level 2 POSCU should be a nurse having specified time in paediatric oncology besides the specific responsibility of the lead nurse role.

Compliance: The named lead nurse, the list of responsibilities and specified time for each POSCU in the CCN agreed by the chair of the CCN.

Note:

For compliance this measure should be fulfilled for each component POSCU in the CCN.

Membership and Terms of Reference of the Children's Cancer Network Co-ordinating Group (CCNCG)

09-7A-107

There should be a children's cancer network co-ordinating group (CCNCG) whose membership includes the following:

- the chair of the CCN (who is also considered to be the chair of the group);
- the lead clinician of the PTC;
- the lead nurse of the PTC (see [appendix 1](#));
- a representative from each POSCU;
- a representative from the trusts in the CCN at CE level (a single representative from the CCN will suffice);
- a representative from the PCTs in the CCN at CE level (a single representative for the CCN will suffice);
- a representative from the SCG(s) relevant to the CCN (a single representative for the CCN will suffice);
- a representative from commissioners specialising in children's commissioning from the CCN's catchment;
- two user/carer representatives;
- one of the NHS employed members should be nominated as having specific responsibility for user/carer's issues and information for patients and carers;
- a representative from each constituent cancer network;
- named secretarial/administrative support.

There should be terms of reference agreed for the CCNCG which include the following:

- the CCNCG should be recognised by the trusts, PCTs and SCGs as the group to which they delegate corporate responsibility in their governance structures for:
 - i) co-ordination and consistency of policy across the CCN for the provision of services for childhood cancer;
 - ii) agreeing childhood cancer service development proposals to the SCG.

Notes:

- *The CCN may choose additional members to the above.*
- *In some cases a single individual may represent more than one of the functions specified above. Reviewers should exercise judgment over this.*
- *The representatives should have delegated authority to make decisions on behalf of all their sector across the CCN (e.g. the PCT representative for all PCTs), if necessary, when acting as a member of the CCNCG.*
- *If the CCNCG is unable to nominate user/carer representatives, but there is an agreed mechanism for obtaining user/carer advice, this measure will be deemed to have been complied with.*
- *The CCNCG has other functions as outlined in the measures.*
- *There may be additional points in the agreed terms of reference.*
- *The CCNCG does **not** have ultimate accountability for children's cancer services. This belongs to the statutory bodies (trusts and PCTs) involved. The CCNCG is accountable within its terms of reference, to the constituent statutory bodies of the CCN.*

MEASURE DETAILS & DEMONSTRATION OF COMPLIANCE

Compliance: The named members, with their role agreed by the chair of the CCN and the trust and PCT CEs and SCGs.
The terms of reference agreed by the acute trust and PCT CEs and SCGs.
The written delegation of authority agreed by trust and PCT CEs and SCGs.

FUNCTIONS OF THE CCNCG (Measures [09-7A-108](#) to [09-7A-133](#))

The responsibility for review purposes for measures [09-7A-108](#) to [09-7A-133](#) lies with the chair of the CCN.

CCNCG meetings

09-7A-108 The CCNCG should meet at least quarterly and record attendance.

Note:

There are no fixed measures for minimum attendance but it is expected that named NHS employed members of the CCN will personally attend a substantial proportion of the meetings rather than rely on deputies. The reviewers should examine the attendance records and use their judgement. A marked lack of compliance with attendance should be a major issue in the report from the peer review.

Compliance: A list of meetings and attendance records in the 12 months, prior to the review/self assessment.

CCNCG Annual Report

09-7A-109 The CCNCG should send annually updated information to its constituent local authorities, statutory and voluntary health care providers and commissioners to inform them of the service improvements and/or developments it has achieved or planned. The information should cover how the CCNCG is addressing any inequalities of care and improvements in cancer outcomes.

Notes:

- *The information may be in the form of an annual report for the CCN and/or in other formats agreed by the board (for example PCT patient prospectuses).*
- *Additional subjects may be covered and the information may be sent to additional organisations.*

Compliance: The annual report (or other formats) covering the year prior to the peer review visit or completed self assessment agreed by the chair of the CCN.
The list of organisations to which the information has been sent.

Note:

For CCNs which are visited two or more years after the publication of these measures the reviewers should see the documents covering each complete year between the publication of these measures and the peer review visit or completed self assessment.

CCNCG Proposals for Service Development

09-7A-110 The CCNCG should make recommendations for the CCN service delivery plan and supporting business case which set the priorities for local delivery plans covering the three years subsequent to the publication of these measures.

The proposals should make reference to:

- service developments;
- facilities developments;
- workforce developments;
- training and education;
- clinical governance and quality improvement development programme;
- data collection.

Note:

It is expected that the service delivery plan will take account of the proposals from the POSCUs and PTC via the relevant locality groups of the host cancer networks.

MEASURE DETAILS & DEMONSTRATION OF COMPLIANCE

Compliance: A summary of the plan, sufficient to show compliance with the measure above.
Written agreement to the plan by the chair of the CCN.
Note:
The summary should be no more than two or three sides.

The configuration of MDTs within the PTC

09-7A-111

CCN Configuration of MDTs within the PTC.

Note:

This measure does not apply to PTC late effects MDTs or POSCU MDTs.

- The CCNCG should agree and declare the disease range which each of the PTC diagnostic and treatment MDTs deals with.
- Each team should be the only PTC diagnostic and treatment MDT for its particular disease range in the CCN.

Note:

This is especially important for certain diseases which may be considered to be part of more than one subspecialty's legitimate practice. For example, lymphoma should not be dealt with by both a solid tumour MDT and a haemato-oncology MDT.

- Each form of children's cancer should be covered by one or other of the PTC MDTs.
- There should be a configuration of late effects MDTs for the PTC which fulfils one of the following:

Either

- 1) A single late effects MDT for the whole children's and TYA's cancer network, covering at least the range of patients whose cancers were initially diagnosed between birth and their 25th birthday

Or

- 2) A single late effects MDT for the whole CCN, covering at least the range of patients whose cancers were initially diagnosed between birth and their 16th birthday; and a single late effects MDT for the whole of the TYAs cancer network, covering at least the range of patients whose cancers were initially diagnosed between the age of 16 and their 25th birthday.

Note:

*There should be only one late effects MDT **planned** to cover a given range of patients. However, the remarks regarding local flexibility over age ranges, according to patients' wishes, apply as earlier in the 'Introduction to the Children's Cancer Measures'.*

Notes:

- *Each declared PTC MDT should be put forward separately for review against the PTC diagnostic and treatment MDT measures ([09-7B-3/4/5](#)) and each team's results of its compliance counts separately towards the peer review of the CCN as a whole.*
- *The core minimum MDT membership needed varies with the subspecialisation (if any) of the team (see measure [09-7B-302](#)).*
- *A late effects MDT which is planned to cover the TYA entry age range, not the children's, should be reviewed as part of the TYA review.*

Compliance: The named PTC MDT(s) with the diseases they deal with and the late effects MDT. The reviewers should check the lack of overlap between teams and their overall collective coverage of children's cancer.

The reviewers should enquire as to the patients the late effects MDT deals with.

Note:

If a given PTC MDT fails to comply with the above criteria this should be a major issue of concern in the peer review report, but that team should still be put forward for review against the relevant measures.

MEASURE DETAILS & DEMONSTRATION OF COMPLIANCE

The CCN and shared care configuration

09-7A-112

The CCNCG and the relevant SCG should agree a shared care configuration for the CCN which specifies the following:

- i) the constituent MDTs and services and their site, in terms of named hospitals of the PTC and each POSCU;
- ii) there should only be one service put forward for review per PTC covering all of the children's cancer chemotherapy for the PTC and only one service per POSCU covering all of the children's cancer chemotherapy for that POSCU
- iii) the named locality of their host cancer network into which the PTC and each POSCU will be incorporated;
- iv) the level of care (1, 2 or 3) to be delivered by each named POSCU;
- v) if there are level 1 POSCUs, which of the four service options they will offer.
- vi) the level 3 POSCUs, if any, which will provide an intrathecal chemotherapy (ITC) service;
- vii) where the following services are delivered in the community;
 - definitive cancer therapy (for example chemotherapy)
 - palliative and supportive care.

The configuration should specify the following for each service:

- the model of service provision, whether out-reach by hospital employees or provision by PTC employees and whether under acute trust governance or PTC governance
- the geographical areas of the CCN which each service covers.

Notes:

The care levels and level 1 services' options are specified in the introduction to children's cancer measures.

It is assumed that every PCT will provide an ITC service.

Compliance: The CCN and shared care configuration agreed by the chair of the CCN and a representative from the SCG.

The reviewers should enquire of the arrangements for the CCN.

Note:

The CCNCG (in agreement with the SCGs) for its compliance with this measure should produce the configuration and the individual POSCUs and the PTC should each agree to abide by it for compliance with their relevant measure.

The initial referral protocol

09-7A-113

The CCNCG should, in consultation with the POSCU MDTs and the PTC diagnosis and treatment MDT, produce an initial referral protocol for children with symptoms and signs suspicious of malignancy for the CCN, which fulfils the following:

- it should provide the agreed contact points and methods of contact for the CCN for urgent referral of children with symptoms and signs of suspicious malignancy;
- it should contain the Department of Health HSC2000/013 referral guidelines for suspected cancer of children;
- it should provide the necessary referral instructions for primary care practitioners; staff in hospitals which host neither a POSCU nor a PTC and staff in hospitals which do host a POSCU or a PTC, but who are not part of the paediatric oncology unit itself.

The initial referral protocol should be distributed to at least the following across the CCN:

- primary care practitioners
- paediatricians
- surgeons who treat children
- accident and emergency departments.

MEASURE DETAILS & DEMONSTRATION OF COMPLIANCE

Compliance: The protocol agreed by the chair of the CCN.
The reviewers should enquire as to the distribution process.
Note:
Minor shortcomings in the completeness of distribution should not preclude compliance.

The diagnosis and staging protocol

09-7A-114 The CCNCG should, in consultation with the POSCU MDTs and the PTC diagnosis and treatment MDT, produce a single diagnosis and staging protocol for the CCN which fulfils the following:

- it should cover the process of initial diagnosis and assessment of stage/extent/severity of the disease and, where considered relevant by the protocol writers, the process of confirmation of relapse/recurrence and its extent/severity;
- it should specify between PTC and POSCUs:
 - i) which establishment is responsible for which investigations;
 - ii) which establishment is responsible for communicating which specified results;
 - iii) the format of the results and mechanisms of communication;
- it may include one or both of the following as considered relevant by the protocol writers:
 - i) instructions common to some or all disease types
 - ii) instructions specific to a named disease type.

Compliance: The protocol agreed by the chair of the CCN.
Note:
The CCNCG, for compliance with this measure, should produce the protocol and the individual POSCU MDTs and the PTC MDT, for compliance with their relevant measures, should agree to abide by it.

CLINICAL MANAGEMENT PROTOCOLS (Measures [09-7A-115](#) to [09-7A-123](#))

Introduction

The CCNCG should, in consultation with the POSCU MDTs and the PTC diagnosis and treatment MDTs, produce a single set of clinical management protocols for the CCN which fulfil the following:

- They should cover how a patient with a given named type of childhood cancer should be treated. This is at the level of which modality of treatment (surgery, radiotherapy, chemotherapy or biological therapy; or which named multi-centre trial), rather than details of individual techniques or regimens. The latter should be agreed across the CCN but for the purposes of peer review they should appear in the CCN list of regimens and in the technique lists of radiotherapy departments.
- They should specify the role of the POSCUs at each level of POSCU care and the role of the PTC in the delivery of the treatment programme.
- They should specify, where relevant, the indications for referral outside the services of the CCN's catchment area, naming the service to which they should then be referred.
Note: These measures contain references to current NSCG designated supra-network centres. Future revisions of the measures will make reference to NSCG centres for any other tumour types as they are designated.
- They should specify, where relevant, the indications for referral to a site specialised MDT dealing with adults, also naming the relevant MDT.
- While addressing the above issues they should be based on the relevant children's cancer and leukaemia group (CCLG) protocol if there is currently one that is applicable. If not, the CCN should agree a network-wide protocol.

These requirements should be fulfilled by a protocol for the disease group specified in each of the subsequent measures ([09-7A-115](#) to [09-7A-123](#)). For compliance with each of these measures the CCNCG should produce the protocol and the individual POSCU MDTs and the PTC diagnostic and treatment MDT, for compliance with their relevant measures, should agree to abide by them.

The Clinical Management Protocols - Leukaemias

09-7A-115 Clinical Management Protocols - Leukaemias
See introduction for details of the measure.

Compliance: The protocol agreed by the chair of the CCN.

MEASURE DETAILS & DEMONSTRATION OF COMPLIANCE

The Clinical Management Protocols - Lymphoma and Reticulo-Endothelial Malignancy

09-7A-116 Clinical Management Protocols - Lymphoma and Reticulo-Endothelial Malignancy
See introduction for details of the measure.

Compliance: The protocol agreed by the chair of the CCN.

The Clinical Management Protocols - CNS Tumours

09-7A-117 Clinical Management Protocols - CNS Tumours
See introduction for details of the measure.

Compliance: The protocol agreed by the chair of the CCN.

The Clinical Management Protocols - Sympathetic Nervous System Tumours

09-7A-118 Clinical Management Protocols - Sympathetic Nervous System Tumours
See introduction for details of the measure.

Compliance: The protocol agreed by the chair of the CCN.

The Clinical Management Protocols - Retinoblastoma

09-7A-119 Clinical Management Protocols - Retinoblastoma
See introduction for details of the measure.
In particular, the protocol should specify that new cases of retinoblastoma should be referred to one of the NSCG designated centres for management.

Compliance: The protocol agreed by the chair of the CCN.

The Clinical Management Protocols - Renal Tumours

09-7A-120 Clinical Management Protocols - Renal Tumours
See introduction for details of the measure.

Compliance: The protocol agreed by the chair of the CCN.

The Clinical Management Protocols - Hepatic Tumours

09-7A-121 Clinical Management Protocols - Hepatic Tumours
See introduction for details of the measure.
In particular, the protocol should specify that new cases of primary hepatic tumours should be referred to one of the NSCG designated liver transplant centres for discussion.

Compliance: The protocol agreed by the chair of the CCN.

The Clinical Management Protocols - Malignant Bone and Soft Tissue Sarcomas

09-7A-122 Clinical Management Protocols- Malignant Bone and Soft Tissue Sarcomas
See introduction for details of the measure.
In particular, the protocol should specify that new cases of primary malignant bone tumours should be referred to one of the NSCG designated bone tumour centres for surgery and possible primary chemotherapy.

Compliance: The protocol agreed by the chair of the CCN.

The Clinical Management Protocols - any other malignancies

09-7A-123 Clinical Management Protocols - Any other malignancies besides those specified in measures [09-7A-115](#) to [09-7A-122](#).
See introduction for details of the measure.

Compliance: The protocols agreed by the chair of the CCN.

MEASURE DETAILS & DEMONSTRATION OF COMPLIANCE

Follow up and long term sequelae protocol

09-7A-124

The CCNCG should, in consultation with the POSCU MDTs and the PTC diagnosis and treatment MDT(s), PTC late effects MDT(s) and the TYA MDT, produce a single follow up and long term sequel protocol for the CCN which fulfils the following:

- it should require (and specify who is responsible for the production of) an end of treatment summary and follow up care plan for each patient completing potentially curative treatment;
- the end of treatment summary and follow up care plan should answer the questions:
 - i) what treatment has been received
 - ii) what is the role of the POSCU MDT and PTC diagnosis and treatment MDT in the patient's follow up and when does their role end
 - iii) what is the role of the PTC late effects MDT and the TYA MDT in the patient's follow up, and when does their role begin
 - iv) which team or teams should be following the patient at which stage of their journey (this may include site specific MDTs)
 - v) which methods of surveillance should be used for late effects of treatment
 - vi) what should be monitored by way of relapse detection and health related quality of life;
- the end of treatment summary and follow up care plan should be completed within six months of completion of potentially curative treatment.

The CCNCG follow up and long term sequel protocol should be distributed to at least the chairs of the network site specific groups in the cancer networks from which the CCN takes referrals.

There should be accompanying instructions which require the ongoing distribution of the protocol to the lead clinicians of all the site specific 'adult' MDTs in the relevant cancer networks.

Compliance: The protocol agreed by the chair of the CCN.

The reviewers should randomly sample some end of treatment summaries.

The reviewers should enquire as to the distribution process.

Notes:

The CCNCG for compliance with this measure should produce the protocol and the individual MDTs, for compliance with their relevant measures, should agree to abide by it. The role of the various MDTs may differ according to the patient's original type of children's cancer, thus the details of the follow up protocol may be, to an extent, disease type specific.

Minor shortcomings in the completeness of distribution should not preclude compliance.

The protocol may alternatively be distributed directly to all MDT lead clinicians.

This measure does not specify the distribution of the protocol to the children's and TYA MDTs of the CCN itself since they are required to agree to it in the course of its production.

CCN medical cover arrangements

09-7A-125

The CCNCG should, in consultation with the PTC and the POSCUs, agree a set of cover arrangements which specify the following:

- i) the circumstances in which a POSCU could receive help from the PTC over specialist medical cover
- ii) the nature of the help which would be provided.

Note:

An example, for illustration only, is that the care of certain categories of patient or the provision of certain procedures could transfer to the PTC in the absence of both the POSCU lead and deputy lead clinicians.

MEASURE DETAILS & DEMONSTRATION OF COMPLIANCE

Compliance: The cover arrangements agreed by the chair of the CCN.

Notes:

There should be one agreed CCN-wide set of arrangements but the details could vary from POSCU to POSCU.

The CCNCG for compliance with this measure should produce the arrangements and the PTC and POSCUs, for compliance with their relevant measures, should agree to abide by them.

CHEMOTHERAPY AND ONCOLOGY PHARMACY MEASURES FOR THE CCNCG (Measures 09-7A-126 to 09-7A-138)

Introduction

Other than surgical treatment and radiotherapy the definitive treatment of children with malignancy, for the purposes of peer review, is considered to be carried out by the specialty of paediatric oncology. Within this group there is usually subspecialisation into paediatric solid tumour treatment specialists and specialists in the treatment of paediatric haematological malignancy. The term paediatric haematology is, for the purpose of peer review, taken to mean the specialty which treats children with non-malignant haematological disorders and is outside the scope of the measures and peer review.

The treatment of children with radiotherapy is carried out by the clinical oncology specialty, usually by specialists who also have an adult radiotherapy practice.

The chemotherapy measures refer to 'the chemotherapy service'. Prior to these measures and the peer review of children's cancer services it may not have been conventional for the staff involved to consider themselves as part of such a defined entity as could be identified by a label like 'the chemotherapy service' -prescribing and administering chemotherapy were just part of the job as a whole.

However, if definite quality measures are going to be applied in reality to the structures and processes involved in children's chemotherapy, then the compliance with these measures has to be verified 'on the ground' in relation to concrete existing practices. Thus, a peer review visit has to relate to a recognised, declared set of people and facilities, with some boundary between them and whoever is going to be reviewed by a different visit. Also this allows for consistency of practice - for example, a set of practice guidelines are understood to apply across the whole of the defined service, which prevents groups of staff disagreeing over practice and asking to be peer reviewed separately.

In the case of children's chemotherapy the service is also defined by the age boundary, with the provisions regarding flexibility as stated in the introduction to the children's cancer measures.

In common with the rest of the Manual for Cancer Services, the responsibility for peer review purposes of every measure is attributed to some named person or other. For chemotherapy this person is termed the 'head of service', which again may be a somewhat new role for some organisations. The same considerations apply to an oncology pharmacy service and the lead pharmacist.

Nomenclature

The term "**chemotherapy**" refers to the use of those cytotoxic agents commonly understood and accepted as being covered by this term. The inclusion of certain other agents which may or may not be understood to fall clearly into this group is permissible, for example biological therapies. The exact extent of the drugs to be included under the remit of the measures is a matter for local discretion unless otherwise stated in the measures themselves. It will largely be manifested by which regimens and which supportive drugs are named in the CCN list and local lists of regimens.

For this set of measures, **systemic, intravenous, intramuscular, oral and subcutaneous** chemotherapy is included. Topical and intracavity chemotherapy is not included. The position regarding **intrathecal** chemotherapy is dealt with separately.

In the measures chemotherapy is referred to as being given over a complete period of treatment known as a **course**, which consists of giving the drugs over a repeated pattern known as a **cycle**. For entirely oral chemotherapy a cycle may be defined by the length of time in between mandatory reviews. The maximum intended number of cycles and therefore the intended length of the course may be pre-determined or **fixed**, or dependent on various factors and therefore **indeterminate or variable** from the outset. The separate occasions when drugs are given within a cycle are termed **administrations**. These are usually understood to refer to occasions of parenteral administration, rather than say daily oral doses, oral treatment being referred to in the conventional way of pharmacological prescriptions.

None of the above terms, as used in these measures, are intended to have any other meanings or connotations other than those stated. Where a measure is intended to refer to a particular level of professional training or seniority, it will be stated. If it is local practice to use different terms, meanings or connotations, this is not a matter for the measures or peer review.

Organisation of the Service

The service is reviewed in three separate components although their activities are inter-related and inter-dependant in practice.

- i) **The networking aspects of chemotherapy.** The CCNCG is subject to measures covering training and its role in the leadership and co-ordination of chemotherapy across the CCN, compliance counting

MEASURE DETAILS & DEMONSTRATION OF COMPLIANCE

towards the review of the CCNCG.

- ii) **The hospital (i.e. Non-community) paediatric chemotherapy activities** within a POSCU or a PTC should, for the purposes of the measures and peer review, be considered as forming a 'service' - the chemotherapy service of that POSCU or PTC. The staff and facilities which are used to deliver this service and the areas of the hospital where this takes place should be declared. There should be no more than one such service put forward for review, per POSCU or per PTC, and all of its paediatric hospital-based chemotherapy activity should be included as being part of that service. Then, this whole service will be peer reviewed against the relevant measures as one complete entity. For example: there should be one and only one person put forward as the head of service for this, for a POSCU or for a PTC; and regarding measures which relate to physical facilities, all the facilities encompassed by the service should be compliant for the service to be considered compliant. Compliance will count towards the review of the core measures of the PTC or POSCU. Similar considerations apply to an oncology pharmacy service (see (iii) below).
- iii) **The oncology pharmacy service** supporting each chemotherapy service will be reviewed as above - i.e. There should only be one oncology pharmacy service for the PTC and one for each POSCU. Compliance will count towards the review of the PTC or of each respective POSCU. The chemotherapy service in the PTC or in a POSCU may receive its pharmacy support from a pharmacy which has previously been reviewed as part of the peer review of "adult" cancer services. If, at such a previous review there was compliance with the measures regarding preparation facilities and COSHH they will be regarded as compliant for the review of children's cancer services, provided it is within the timeframes stated in those measures. The remaining oncology pharmacy measures should be applied specifically and separately with regards to the children's service.

Chemotherapy activity in the community is reviewed only so far as the training and authorisation of nurses administering an agreed list of low risk regimens and the responsibility, apart from that of the CCNCG, lies with the PTC, POSCU or PCT, depending on who employs the nurses.

Intrathecal Chemotherapy

Separate measures for the review of intrathecal chemotherapy have been written, based on the National Guidance on Intrathecal Chemotherapy ([HSC 2003/010](#)). These are the responsibility of the CE of each trust which delivers ITC. The ITC review is being carried out trust by trust for adult as well as children's chemotherapy. The measures, which are the same for adults and children, are contained in a separate section, section [3S-3](#) of the Manual for Cancer Services, and instructions on how paediatric oncology relates to this are contained therein.

It is important for reviewers to read the notes on Integration of Intrathecal Chemotherapy Measures, with the General Measures on Chemotherapy: Manual of Cancer Services. Chemotherapy specific measures appendix A, page 41. The same principles on this issue apply when reviewing children's intrathecal chemotherapy. Whether a given POSCU should be delivering intrathecal chemotherapy is a matter to be agreed with the CCNCG.

LEADERSHIP OF THE SERVICES (Measures [09-7A-126](#) to [09-7A-129](#))

Introduction

Following on from the concept of a chemotherapy and oncology pharmacy service, which is declared and defined sufficiently for it to be peer reviewed, there is the concept of a lead person who is able to co-ordinate and facilitate any developments needed for compliance with the measures.

Head of service for chemotherapy for the PTC

09-7A-126

- The CCNCG should agree, in consultation with the lead cancer clinician(s) of the acute trust(s) involved, a single named head of service for chemotherapy for the PTC.
- They should have regular involvement in the use of chemotherapy in paediatric oncology as part of their list of responsibilities or work plan besides their specific duties as head of service.

Note:

The head of service would normally be the lead clinician of the PTC, but may be a nursing or pharmacist practitioner and may or may not be a lead nurse or lead pharmacist.

Compliance: The named head of service agreed by the chair of the CCNCG and the lead cancer clinician(s) of the acute trust(s).

The reviewers should enquire of the head of service's timetable as evidence of their involvement in the treatment of patients with chemotherapy.

MEASURE DETAILS & DEMONSTRATION OF COMPLIANCE

Head of service for chemotherapy for each POSCU

09-7A-127

- The CCNCG should agree, in consultation with the lead cancer clinicians of the acute trusts involved, a single named head of service for chemotherapy for each POSCU in the CCN from where chemotherapy is being dispensed.
- They should have regular involvement in the use of chemotherapy in paediatric oncology as part of their list of responsibilities or work plan, besides their specific duties as heads of service.

Note:

The head of service would normally be the lead clinicians of the POSCUs but may be nursing or pharmacist practitioners and may or may not be lead nurses or lead pharmacists.

Compliance: The named heads of service agreed by the chair of the CCNCG and the acute trust lead clinicians.

The reviewers should enquire of the heads of service's timetables as evidence of their involvement in the treatment of patients with chemotherapy.

Lead pharmacist for the PTC oncology pharmacy service

09-7A-128

The CCNCG should agree, in consultation with the lead cancer clinician(s) of the acute trust(s) involved, a single named lead pharmacist for the PTC oncology pharmacy service, who should be one of the designated oncology pharmacists.

Note:

If the hospital also hosts an oncology pharmacy service for adults the 'adult' lead pharmacist could also be agreed as the lead pharmacist for the children's service

Compliance: The named lead pharmacist for the service agreed by the chair of the CCNCG and the lead clinician(s) of the acute trust(s) involved.

Lead pharmacist for each POSCU oncology pharmacy service

09-7A-129

The CCNCG should agree, in consultation with the lead cancer clinicians of the acute trusts involved, a single named lead pharmacist for each POSCU oncology pharmacy service in the CCN who should be one of the designated oncology pharmacists.

Note:

If the hospital also hosts an oncology pharmacy service for adults the 'adult' lead pharmacist could also be agreed as the lead pharmacist for the children's service.

Compliance: The named lead pharmacist for each POSCU oncology pharmacy service agreed by the chair of the CCNCG and the lead clinicians of the acute trusts involved.

CO-ORDINATION OF THE SERVICES (Measures [09-7A-130](#) to [09-7A-133](#))

For this aspect of the role of the CCNCG - see the relevant items in measure [09-7A-107](#) regarding terms of reference of the CCNCG in addition to the measures below.

CCN agreed list of acceptable chemotherapy regimens

09-7A-130

The CCNCG, in consultation with the PTC and POSCUs, should agree a list of acceptable chemotherapy regimens for the CCN across the PTC and all POSCUs and levels including community services. It should be updated annually.

Notes:

The list should cover all agreed chemotherapy for solid tumour oncology and haemato-oncology in the CCN, including those regimens which are agreed as deliverable in the community.

- *The intention is not to require a single mandatory regimen for each clinical indication. It is to prevent individual practitioners having unorthodox obsolete and unpredictably varying practice, which is against the opinion of their peers within the CCN.*
- *The CCNCG should produce the list for its compliance with this measure and the*

MEASURE DETAILS & DEMONSTRATION OF COMPLIANCE

PTC and POSCUs should produce a compatible list for their own service (for their compliance with their relevant measure).

- *The CCN list may have a number of alternative regimens for a particular clinical indication, of which a local group need only agree those which it intends to use in its service. A local group need only address those clinical indications which are applicable to the scope of its practice. The key requirement is that all regimens on the local group's list are compatible with the CCN's list.*
- *Each regimen on the list should be accompanied by the following minimum, regimen-specific, information:*
 - *cancer type*
 - *name of regimen, therapeutic intent(s), palliative/adjuvant/neo-adjuvant/radical*, as applicable*
 - *cytotoxic drugs*
 - *doses (per m² or Kg as applicable)*
 - *routes of administration*
 - *number of cycles or whether this is indeterminate*
 - *length of cycle and schedule of administrations within a cycle*
 - *mandatory tests prior to a course and individual cycle*
 - *mandatory supportive drugs with each cycle*
 - *mandatory cytotoxic dose modifications and their indications.*

**Radical can be taken to mean with the intent to produce complete remission leading to potential cure or significant prolongation of life.*

- *This measure should include oral chemotherapy regimens.*

Compliance: The list (or the updates see below) for the year prior to the peer review visit or completed self assessment, either as a hard copy document or as part of a computerised prescribing system, agreed by the chair of the CCNCG.

For CCNCGs, meeting for two or more years since the publication of the measures, the lists are needed from the first year, then the agreed updates for each subsequent complete year up to the peer review visit or completed self assessment.

Policy for preventing regular use of regimens not on the accepted list

09-7A-131

The CCNCG should agree a written policy in consultation with the PTC chemotherapy group for preventing regular use of regimens not on the accepted list.

The policy should state:

- the exceptional circumstances under which such a regimen **could** be used;
- the procedure which is then required to authorise and record it.

Note:

The CCNCG should produce this policy for compliance with this measure and the local group should agree to abide by it for its compliance with its relevant measure.

Compliance: The policy agreed by the chair of the CCNCG.

Annual review of the use of regimens not on the accepted list

09-7A-132

The CCNCG should annually review the records from the CCN's chemotherapy services of the use of regimens which are not on the agreed list.

Note:

It may not be possible to review all the chemotherapy services at one meeting.

Compliance: Documentation (eg an extract of minutes or an agenda) to show that a review meeting took place in the year prior to the peer review visit or completed self assessment.

MEASURE DETAILS & DEMONSTRATION OF COMPLIANCE

CCN common guidelines on chemotherapy complications

09-7A-133 There should be common guidelines/protocols throughout the CCN on at least the following issues:

- i) cytotoxic administration techniques
- ii) the care of venous access devices used in the hospitals, including the treatment of line complications
- iii) the recognition and treatment of cytotoxic extravasation
- iv) the recognition and treatment of allergic reactions including anaphylaxis
- v) the use of blood products.

Compliance: The written guidelines/protocols from across the CCN.

Note:

If the PTC and POSCUs have guidelines on these topics but they are not in agreement with CCNCG guidelines the responsibility for peer review purposes lies with the CCNCG.

CCN INTERNAL TRAINING (Measures [09-7A-134](#) to [09-7A-137](#))

CCN internal training programme

09-7A-134 The CCNCG should agree a nurses' training programme in oncology skills and chemotherapy administration for the CCN.

- the programme should specify the methods and length of training;
- the programme should specify the three distinct types of internal training as defined in the introduction to the children's cancer measures (full, foundation and low risk); related to each other as in the introduction, such that nurses can be potentially trained and assessed for any one separate type;
- the programme should cover at least the competencies set out in the introduction.

Note:

See separate measure on the training of medical staff in administration of chemotherapy.

Compliance: A summary of the programme agreed by the chair of the CCNCG sufficient to show compliance with the measure.

Note:

For compliance with this measure, the CCNCG should produce the programme and the individual chemotherapy services, for compliance with their relevant measures, should agree to it.

CCN training for medical staff administering chemotherapy

09-7A-135 The CCNCG, in consultation with the chemotherapy heads of service, should agree which parts of the internal training programme (see measure [09-7A-134](#)) and which methods of training and assessment should be used for medically qualified staff in the CCN, who are required to potentially administer systemic intravenous chemotherapy as part of their duties.

Note:

Measures for medical staff training in the administering of intrathecal chemotherapy are addressed in the ITC section of the manual for cancer services.

Compliance: The parts of the programme, the review and training method agreed by the chair of the CCNCG.

CCN list of low risk regimens

09-7A-136 The CCNCG, in consultation with the chemotherapy heads of service, should agree those low risk regimens or parts of regimens via which routes of administration and in which settings they may be delivered by nurses who have only received training at the low risk level specified in the introduction.

Notes:

- *This arrangement could be used to cover the practice of nurses delivering certain*

MEASURE DETAILS & DEMONSTRATION OF COMPLIANCE

low risk treatments in the community.

- *It is currently considered, for example, that the IV bolus 'low risk' cytosine falls into this category.*

Compliance: The list of regimens or parts of regimens, routes and settings agreed by the chair of the CCNCG.

CCN training and qualifications for staff for the 24-hour telephone advice service

09-7A-137

The CCNCG should agree a policy for the minimum acceptable specialist training and/or qualifications for nursing, medical staff and therapeutic radiographers to take part in the 24-hour telephone advice service.

Note:

For nursing staff it would be expected that this would be in terms of the training types (internal and external) specified in the introduction.

Compliance: The training and/or qualification levels agreed by the chair of the CCNCG.

CCN guidelines/protocols for the referral of patients with complications related to chemotherapy

Introduction

These guidelines are intended to relate to an agreed integrated arrangement for the CCN, with agreed, locally relevant contact points. Thus, it is a measure for the CCNCG, acting in consultation with the chemotherapy services across the CCN.

CCN guidelines/protocols for the referral of patients with complications related to chemotherapy

09-7A-138

The CCNCG, in consultation with the chemotherapy heads of service, should agree guidelines/protocols for the CCN for referral of patients with acute complications related to chemotherapy and/or symptoms suggestive of those complication, They should fulfil at least the following criteria:

- They should cover symptoms and signs suggestive of, and indications for referral with the following:
 - neutropenic sepsis
 - cytotoxic extravasation
 - nausea and vomiting
 - stomatis, diarrhoea and other mucositis
 - complications associated with venous access devices.
- They should specify the agreed local contact points for advice or acceptance of patients with these complications or symptoms or signs of them, the contact points being as relevant to each respective geographical part of the CCN.
- The contact points should be compatible with the services and responsibilities agreed for the POSCUs. (Topic [7A](#), The CCN and shared care configuration).
- They should be distributed to at least the following in the CCN:
 - primary care practices and polyclinics
 - PCT cancer leads
 - A&E departments
 - consultant paediatricians
 - acute paediatric wards
 - NHS direct services
 - NHS walk-in centres
 - out of hours primary care service providers.

Compliance: The guidelines/protocols agreed by the chair of the CCNCG and the relevant heads of service.

Note:

Minor shortcomings in the completeness of distribution should not preclude compliance with the measure.

MEASURE DETAILS & DEMONSTRATION OF COMPLIANCE

RADICAL RADIOTHERAPY FOR CHILDREN (Measures [09-7A-139](#) to [09-7A-140](#))

CCN radical radiotherapy policy

09-7A-139

The CCNCG should agree a policy specifying that:

- radical courses of radiotherapy for children and/or all radiotherapy treatment needing sedation or general anaesthesia should only be delivered in a single, named radiotherapy department for the CCN;
- they should only be delivered under the care of a clinical oncologist who is a core member of the PTC diagnostic and treatment MDT.

Compliance: The policy naming the department, agreed by the chair of the CCNCG and all the radiotherapy departments' heads of service in the CCN.

The reviewers should enquire as to the working practice in the CCN.

Note:

The department agreed as delivering radical treatment for children should be put forward for review against the radiotherapy measures in the PTC core measures section.

CCN palliative radiotherapy policy

09-7A-140

The CCNCG should agree a policy specifying that:

- palliative courses of radiotherapy for children not needing sedation or general anaesthesia may be delivered in any radiotherapy department in the CCN under the care of any clinical oncologist, provided the proposed course is discussed with a core consultant member of the PTC diagnostic and treatment MDT prior to the treatment.

Compliance: The policy agreed by the chair of the CCNCG and all the radiotherapy departments' heads of service in the CCN.

Note:

The CCNCG may agree a more restrictive policy than this if it chooses. This would also be compliant.

CCN psychosocial assessment guidelines

09-7A-141

The CCNCG should, in consultation with the MDTs, agree CCN-wide guidelines for psychosocial assessment of patients and carers, which specify at least the following:

- i) the assessment should include:
 - information needs
 - coping skills
 - practical support issues
 - social and cultural circumstances
 - education related issues
 - employment related issues
 - psychological, emotional and spiritual issues;
- ii) the patient, their family and other relevant carers should be included in the assessment;
- iii) the assessment should be considered on at least the following points in the care pathway:
 - diagnosis
 - during definitive treatment
 - during post-treatment follow up
 - at relapse
 - during palliative care
 - (for family and carers) at bereavement.

Compliance: The guidelines agreed by the chair of the CCNCG.

Note:

For compliance with this measure the CCNCG should produce the guidelines and the MDTs for compliance with their relevant team measures should agree to abide by them.

MEASURE DETAILS & DEMONSTRATION OF COMPLIANCE

CLINICAL TRIALS (Measures [09-7A-142](#) to [09-7A-143](#))

CCN list of trials and studies

09-7A-142

The CCNCG should agree a list, updated annually, of CCLG - endorsed trials and studies into which patients from the CCN should be entered and for which numbers entered will be recorded.

Note:

The timing of the year to which the list and the recruitment period refer will be agreed with the CCLG.

Compliance: The list or the update, as relevant, agreed by the chair of the CCNCG.

CCN annual clinical trials discussion

09-7A-143

There should be an annual discussion regarding the CCN's entry of patients into clinical trials, which fulfils the following:

- it should relate to the previous year's clinical trial activity. (See note in measure [09-7A-142](#));
- it should be between at least the Chair of the CCNCG, the lead clinician of the PTC Diagnostic and Treatment MDT and a representative of the CCLG;
- it should make reference to the CCN's list of agreed trials and studies, addressing any issues affecting incorporation or non-incorporation of trials and studies on to the list;
- it should make reference to the numbers of patients recruited into each one, addressing any issues affecting recruitment;
- it should agree and record proposed remedial actions resulting from the discussion to improve recruitment into trials.

Compliance: A relevant extract of the minutes of a meeting showing the relevant minimum attendance and agreement of remedial actions.

Note:

A tele-conference or video-conference could be compliant.

TOPIC 09-7B-1 - PRINCIPLE TREATMENT CENTRE (PTC) CORE MEASURES

Introduction

The responsibility for review purposes for the measures [09-7B-101](#) to [09-7B-135](#) lies with the lead clinician of the PTC.

<i>MEASURE DETAILS & DEMONSTRATION OF COMPLIANCE</i>	
PTC FACILITIES MEASURES (Measures 09-7B-101 to 09-7B-110)	
Policy for the place of inpatient chemotherapy delivery	
09-7B-101	<p>There should be a written policy whereby inpatient chemotherapy (where patients stay overnight) should only be given on named wards where it is agreed as part of the ward's regular activity and to which such patients are admitted in preference to other wards.</p> <p><i>Notes:</i></p> <ul style="list-style-type: none"> • <i>Day care chemotherapy may also be given on such wards.</i> • <i>Wards with stricter policies than above, for example those reserved exclusively for chemotherapy, are also considered compliant with this measure.</i> <p><i>Compliance:</i> The policy, naming the wards, agreed between the head of service and the relevant hospital manager. The reviewers should enquire of the hospital's working practice.</p>
Policy for the place of outpatient chemotherapy delivery	
09-7B-102	<p>When outpatient or day care chemotherapy is being given in wards/areas other than those specified in the above measure, it should only be given in specified outpatient/day care room(s) covered by a policy whereby:</p> <ul style="list-style-type: none"> • on the days that chemotherapy is being given the room(s) should only be used for this purpose or other outpatient/day care clean treatment or procedures. <p><i>Note:</i> <i>Such terms as departments, units, suites and facilities, etc are all difficult to define with precision but they are all made up of a room or rooms.</i></p> <p><i>Compliance:</i> The policy specifying the room(s) agreed between the head of service and the relevant hospital manager. The reviewers should enquire of the hospital's working practice.</p>
Availability of specified regimens/protocols/emergency equipment	
09-7B-103	<p>The areas/wards/rooms identified in measures 09-7B-101 and 09-7B-102 should have available to them:</p> <ul style="list-style-type: none"> • the regimen details for the regimens in use; • protocol documents and equipment for the management of at least the following emergencies; • anaphylactic shock; • extravasation of cytotoxics; • cardiac arrest; • spillage of cytotoxics. <p><i>Compliance:</i> The reviewers should inspect the information in those locations.</p>

MEASURE DETAILS & DEMONSTRATION OF COMPLIANCE

Area for temporary storage of chemotherapy agents

09-7B-104 The areas/wards/rooms identified in measures [09-7B-101](#) and [09-7B-102](#) should have within them, or adjacent to them, a separate and identified area for the temporary storage of chemotherapy agents which have been dispensed from pharmacy and for tasks involved in preparation and delivery of treatment.

The storage area should have a lockable fridge and cupboard specifically for the storage of chemotherapy agents.

Note:

These tasks refer to those which the service decides do not need to be done in a specialised, clean pharmacy preparation unit.

Compliance: The reviewers should view the rooms.

Availability of single rooms for inpatient isolation

09-7B-105 The PTC should have an agreed number of single rooms (not one room only) to be used for inpatient isolation, each with en-suite toilet and washing facilities.

Note:

It would be expected that such rooms would count towards the number of operational oncology beds (measure [09-7B-114](#)).

Compliance: The number, agreed by the head of service and the relevant hospital manager.
The reviewers should view the rooms.

Area for paediatric oncology clinic

09-7B-106 The outpatient clinic specified in the 'paediatric oncology clinic' (measure [09-7B-110](#)) should be held such that it, together with its waiting area, is spatially or temporally separated from all other outpatient clinics.

Compliance: The hospital outpatient department's weekly schedule.
If relevant, the reviewers should view the department.

Note:

This measure is designed to reduce the exposure of patients to the risk of cross-infection.

DAY CARE/OUTPATIENT TREATMENT FACILITIES (Measures [09-7B-107](#) to [09-7B-110](#))

Day care waiting room

09-7B-107 A waiting room exclusive to the use of patients and carers using the day care facility on the days it is being used as such.

Compliance: The reviewers should enquire as to the hospital's working practice.

Note:

Practices more rigorous than this - i.e. waiting areas permanently exclusive to such patients, obviously also comply.

Availability of day care paediatric resuscitation equipment

09-7B-108 Paediatric resuscitation equipment in the room(s) where day care treatment takes place. There should be an equipment check at least weekly.

Compliance: The reviewers should view the equipment and enquire as to the hospital's working practice.

Note:

*This measure is **not** intended to produce a detailed inspection with compliance being decided on the precise contents and type of the equipment.*

Day care recovery rooms

09-7B-109 Day care recovery beds, i.e. a ward or room(s) with day beds covered by a policy whereby:

- on the days that the PTC's day care facility is being used, the rooms are used only for its patients who are resting after day care treatments or after invasive

MEASURE DETAILS & DEMONSTRATION OF COMPLIANCE

investigation, or for other outpatients who have had clean day care procedures.

Note:

The above facility is required but it is acceptable practice for children to recover initially in a general recovery area before transferring to a children's recovery area.

Compliance: The policy, specifying the rooms, agreed by the head of service and the relevant hospital manager.
The reviewers should view the facilities.

Paediatric oncology clinic

09-7B-110 There should be a regular (scheduled) outpatient clinic at a host hospital of the PTC which:

- i) should be identified in the hospital's outpatient department clinic list or timetable as a clinic for patients under the care of the PTC;
- ii) should be exclusive to patients under the care of the PTC as opposed to including other paediatric outpatients;
- iii) should be identified, together with a contact point for referral, in the primary care referral guidelines specified in measure [09-7A-113](#);
- iv) should have the lead clinician of the PTC as a member of its medical staffing.

Compliance: Hospital outpatient department timetable or clinic list.
For point (ii) the reviewers should enquire as to the hospital's working practice.
The relevant extract from the primary care referral guidelines.
Work plan of the lead clinician of the PTC.

NURSE NUMBERS AND TRAINING LEVELS (Measures [09-7B-111](#) to [09-7B-121](#))

Introductory Note

It is an underlying assumption of these measures that where a 'nurse' is referred to without any further specification this refers to a 'registered sick children's nurse', or 'registered nurse (child)'. Any further qualifications referred to are in addition to these initial qualifications.

The oncology ward

Note:

The term oncology ward is used for peer review purposes only to denote the ward which is defined in the measure below. The local name for such a ward or any other specialties which may occupy this ward is not subject to review.

The oncology ward

09-7B-111 There should be a written policy whereby paediatric oncology patients should be cared for on a single named children's ward where this is agreed as part of the ward's regular activity and to which patients are admitted in preference to other wards.

Notes:

- *Where there is only one ward for children in the host hospital of the PTC this is automatically compliant.*
- *Where there is a ward reserved exclusively for paediatric oncology patients this is automatically compliant.*
- *This measure does not apply to oncology patients who are being nursed on a separate paediatric HDU or ITU. The RCN recommendation on nursing staff numbers for these facilities are separately covered in the RCN guidance by sections which are not cancer-specific.*
- *Similarly, this measure applies only to children undergoing non-surgical oncology treatment, or supportive care related to that. Those undergoing surgery should be accommodated on wards where the relevant specialist pre and post operative care is available.*
- *The wording of the RCN guidance for nursing staff numbers on specialised units implies that the underlying model is one where all the patients in question are nursed on a single ward.*

MEASURE DETAILS & DEMONSTRATION OF COMPLIANCE

- *If, however, in the largest PTCs, it is the intended policy that oncology patients will be nursed on more than one paediatric ward, the ward staffing measures should be applied to each ward separately and each ward would need to comply for overall compliance for the PTC. In this case, this measure requires an agreed policy that names each of the intended wards; that this is part of each ward's regular activity and that patients are admitted to them in preference to wards not named in the policy.*

Compliance: The policy, naming the ward, agreed between the lead clinician of the PTC and the relevant hospital manager.
The reviewers should enquire of the hospitals practice.

Nursing establishment for oncology ward

09-7B-112

The number for the oncology nursing establishment for the oncology ward should be based on the nurse numbers for the operational oncology beds, as recommended by the Royal College of Nurses document (RCN) 'Defining Staffing Levels for Children's and Young Adult's Services' 2003, sections 7 and 5. All such nurses should be Registered Sick Children's Nurses (RSCN or RN [child]).

Note:

The measure requiring the number of operational oncology beds to be agreed is measure [09-7B-114](#).

For guidance purposes for peer review:

- *For operational oncology bed numbers of five or less there should be an establishment intended to provide two nurses day and night for the oncology patients.*
- *For six or more operational oncology beds a third of the beds should be considered as needing high dependency care (one nurse to two patients). The remaining two thirds require one nurse for three patients.*

Compliance: The nursing establishment.
The number of operational oncology beds.
Both agreed by the lead clinician and lead nurse of the PTC and the relevant hospital manager.

Bed occupancy

09-7B-113

There should have been an assessment of the average daily bed usage of the oncology ward, using data from a specified period during the two-year period prior to the peer review visit or completed self assessment. The assessment should fulfil the following:

- the specified period should be at least six months (but see the instructions on annual activities below);
- it should take into account all patients admitted under the care of the paediatric oncologists;
- it may use previous estimates of average annual patient numbers in the above categories, made during the two years prior to the peer review visit;
- it should be used to estimate the average bed usage for oncology patients on the oncology ward.

Compliance: The results of the assessment.
The estimated average bed usage.
The reviewers should enquire as to how the assessment was undertaken.

Note:

The numerical values of the results are not subject to review - they are required only as evidence that the assessment has been performed.

MEASURE DETAILS & DEMONSTRATION OF COMPLIANCE

Operational oncology beds

09-7B-114 From the estimated average bed usage a figure for the planning number of operational oncology beds should be agreed with the relevant hospital manager, for purposes of agreeing the oncology ward nursing establishment

Compliance: The planning number of operational oncology beds, agreed by the lead clinician and the lead nurse of the PTC and the relevant hospital manager.

Notes:

The numerical value itself is not subject to review.

If there is lack of agreement over the proposed number of operational oncology beds, this measure is not compliant and this should be explicitly mentioned in the peer review report.

If, however, there is a previous number of operational oncology beds which is being used the measures on nurse numbers should be applied using this.

Audit of operational oncology bed usage

09-7B-115 There should be an audit over a continuous 12 month period, subsequent to the agreement over the number of operational oncology beds, for the PTC. The audit should be of the following:

- the total number of separate paediatric oncology admissions to the hospital hosting the oncology ward of the PTC, which have occurred when on initial admission the number of current oncology inpatients on the oncology ward exceeded the number of operational oncology beds, i.e. this is an audit of the number of times the agreed number of operational oncology beds were already fully occupied at the time of a patient's admission.

Notes:

- *The particular 12 month period should be agreed with the lead clinician of the PTC.*
- *The PTC may wish to record additional, related parameters as part of this audit. These are not subject to review.*

Number of separate admissions, not patients, is the figure being audited.

Compliance: The results of the audit agreed by the lead clinician of the PTC.

Note:

The results themselves in the sense of the level of performance (for example number of admissions against a recommended minimum) are not subject to review. They are evidence that the audit has been performed. The PTC may choose to use them in whatever way it wishes.

TRAINING FOR ONCOLOGY WARD NURSES (Measures [09-7B-116](#) to [09-7B-118](#))

Note:

These measures should be applied with reference to the model and exemptions shown in the introduction to the children's cancer measures.

Full internal training for oncology ward nurses

09-7B-116 A minimum of two, day and night, of the nurses allocated to the operational oncology beds should be trained at least to the 'full internal' training level as specified in the introduction.

Compliance: The number (head count) allocated to oncology beds, day and night.
The training confirmation of the relevant nurses.

MEASURE DETAILS & DEMONSTRATION OF COMPLIANCE

Foundation internal training for oncology ward nurses

09-7B-117 Once the minimum of two, day and night, trained nurses measure is met with (measure [09-7B-116](#)) then where the number of nurses allocated increases with increasing numbers of operational beds, 70% of the overall number allocated to the operational oncology beds should be trained at least to the 'internal foundation' training level as specified in the introduction.

Compliance: The head count and training confirmation of the relevant nurses.

External training for oncology ward nurses

09-7B-118 All the nurses of band 6 or above working on the oncology ward should be trained to the 'external' training level as specified in the introduction.

Compliance: The training confirmation of the relevant nurses.

TRAINING FOR DAY CARE FACILITY NURSES (Measures [09-7B-119](#) to [09-7B-121](#))

Note:

These measures should be applied with reference to the model and exemptions shown in the introduction to the children's cancer measures.

Full internal training for day care nurses

09-7B-119 A minimum of two nurses on duty during each shift of each working day that the day care facility is open for chemotherapy should be trained at least to the 'full internal' training level as specified in the introduction.

On days that the facility is open, but not for chemotherapy, there should be a minimum of two nurses during each shift trained at least to the 'foundation internal' level as specified in the introduction.

Compliance: The number (head count) and the training confirmation of the relevant nurses.

Foundation internal training for day care nurses

09-7B-120 70% of the nurses overall allocated to the day care facility should be trained at least to the 'foundation internal' level, as specified in the introduction.

Compliance: The head count and training confirmation of the relevant nurses.

External training for day care nurses

09-7B-121 All the nurses of band 6 or above allocated to the day care facility should be trained according to the 'external training' level as specified in the introduction.

Compliance: The training confirmation of the relevant nurses.

MEDICAL STAFFING (Measures [09-7B-122](#) to [09-7B-124](#))

Introduction

There is no measure requiring a deputy lead clinician for the PTC, unlike the POSCU, since there is a requirement for five consultant oncologists in the PTC. Whether one of them is designated to a deputy lead is at the PTC's discretion.

Consultant rota

09-7B-122 There should be an on-call rota for the PTC which fulfils the following:

- it should be staffed wholly by named consultants, each of whom is a paediatric oncologist employed at the PTC and providing inpatient care as a part of their timetable during normal working hours;
- it should provide 24/7 cover;
- the on-call individual should be available for giving advice to enquiring clinicians regarding paediatric oncology patients being managed anywhere in the CCN, whether in hospital or in the community;
- the on-call individual should be available to attend hospital facilities of the PTC when required;

MEASURE DETAILS & DEMONSTRATION OF COMPLIANCE

- there should be a minimum of five individual consultants.

Notes:

- *The remit of the cover rota may be greater than that specified above, for example the consultants may be available for advice to non clinicians and there may be consultants available for advice from other specialties related to the treatment of children's cancer. This is not subject to review.*
- *The oncologists should be paediatric oncologists but should not be drawn from clinical oncologists who have no responsibility for chemotherapy for children.*

Compliance: The rota, with named consultants, agreed by the lead clinician of the PTC.
The reviewers should enquire as to the working practice of the PTC to verify the remit of the cover rota (bullet points three and four).

Resident cover rota

09-7B-123

There should be a resident cover rota for the PTC whereby there is 24/7 resident on-call cover from medical staff in paediatrics of ST3 minimum level of seniority.

Notes:

- *Non-consultant specialist career grades may also take part.*
- *Medical staff on the rota may specialise in paediatric oncology or general paediatrics or other branches of acute paediatrics.*

Compliance: The rota, showing named doctors, agreed by the lead clinician of the PTC.

CCN medical cover arrangements

09-7B-124

The PTC should agree its role in the CCN medical cover arrangements (measure [09-7A-125](#)).

Compliance: The cover arrangements agreed by the lead clinician of the PTC.

Note:

The CCNCG for compliance with their relevant measures should produce the arrangements and the PTC, for compliance with this measure, should agree to abide by them.

Other staffing for the PTC

09-7B-125

There should be the following number of WTEs of staff, designated for paediatric oncology employed by the hospital(s) of the PTC, per unit of 80 new cases of children's cancer per year:

- 1 dietician
- 1 physiotherapist
- 1 occupational therapist
- 3 play specialists
- 5 paediatric oncology outreach nurses
- 1.5 pharmacists (specialist paediatric oncology pharmacists)
- 1 clinical psychologist.

Notes:

- *The scaling should be done to the nearest 0.5 of a WTE.*
- *There should be no scaling down below 80 cases as the model of 80 new cases per year is considered to be an appropriate minimum critical mass for viability.*
- *'New case' means new registration de novo not a repeat presentation with relapse or recurrence.*
- *The number of new cases per year should be taken as an average over the two complete calendar year prior to the peer review.*
- *The number of hospital based nurses is not included as this is dealt with by measures elsewhere.*
- *The number of paediatric oncologists is not included as the parameter of five*

MEASURE DETAILS & DEMONSTRATION OF COMPLIANCE

oncologists was based on ability to provide a 24/7 cover rota, not primarily on a workload measure based on number of new cases. Increasing oncology input with increasing case numbers may be desirable but is not currently covered by the measure and peer review. Some other groups of medical staff are covered by other children's cancer measures, other measures in Manual of Cancer Services or are outside the scope of peer review.

- Some other groups, for example social workers and research staff, are not included as outside mandatory peer review requirements, being employed from outside the NHS in the majority of cases.

Compliance: The WTEs of each staff group and the average numbers of new cases per year, agreed by the lead clinician of the PTC.

Protocol co-ordinator

09-7B-126

There should be a named person at the PTC, who should be a core member of a PTC MDT, who has the responsibility for receiving, acknowledging, archiving and distributing CCN protocols and protocol amendments.

They should agree a list of responsibilities of the role with the lead clinician of the PTC.

Note:

The person need not be a clinician. The role need not necessarily be full time but should have specified time in their job description.

Compliance: The named person agreed by the lead clinician of the PTC.
The list of responsibilities agreed by the lead clinician of the PTC.
The specified time.

Cancer services directory

09-7B-127

The following should be included in the cancer services directory of the PTC's locality:

- i) the core members of the PTC diagnosis and treatment MDT and the contact point for the team;
- ii) the core members of the PTC late effects MDT and the contact point for the team;
- iii) the location and core members of the POSCU MDTs in the CCN and the contact points for these MDTs;
- iv) the location and core members of the TYA MDT and the contact point of the team;
- v) the location and contact points for the PTC chemotherapy service;
- vi) the contact points for the 24 hour telephone advice service;
- vii) the location and contact points for the PTC paediatric radiotherapy service;
- viii) the contact point for the paediatric oncology palliative care service and 24-hour palliative care advice;
- ix) the patients' and carers' support groups which the CCNCG endorses (see measure [09-7A-125](#)) with local contact points.

Note:

This directory may include additional information on paediatric oncology services.

Compliance: The cancer services directory of the PTC's locality agreed by the chair of the locality group.

24-hour telephone advice service for patients and carers

09-7B-128

The PTC should be responsible for the provision of a telephone advice service for patients with children's malignancy and their carers. The service should fulfil the following:

- it should be available 24-hours a day, seven days a week, every day of the year;
- administrating the staff rota should be the responsibility of the PTC, but staff on it may be from the PTC or a POSCU;
- there should be one or more contact points for the service overall, but for any given part of the catchment area there should be only a single contact point;
- staffing may be by nurses or medical staff or a combination;

MEASURE DETAILS & DEMONSTRATION OF COMPLIANCE

- the minimum permissible level of training or qualifications of a staff member on the rota should be agreed by the CCNCG;
- there should be a 24 hours a day, seven days a week rota whereby a consultant paediatrician oncologist is permanently available to give telephone advice when required to the staff members of the patients and carers advice service;
- the contact point for information should be distributed to all new patients and their carers.

Note:

Therapeutic radiographers may be used for advice on radiotherapy issues.

Compliance: The reviewers should enquire of the working practice of the PTC.
An example of the advice rota with named staff.
An example of the consultants' rota.
The reviewers should enquire as to the distribution process.

THE PRINCIPAL TREATMENT CENTRE (PTC) CHEMOTHERAPY MEASURES (Measures [09-7B-129](#) to [09-7B-162](#))

Introduction

Other than surgical treatment and radiotherapy, the definitive treatment of children with malignancy for the purpose of peer review is considered to be carried out by the specialty of paediatric oncology. Within this group there is usually subspecialisation into paediatric solid tumour treatment specialists and specialists in the treatment of paediatric haematological malignancy. The term paediatric haematology is, for the purpose of peer review, taken to mean the specialty which treats children with non-malignant haematological disorders and is outside the scope of the measures and peer review.

The treatment of children with radiotherapy is carried out by the clinical oncology specialty, usually by specialists who also have an adult radiotherapy practice.

The chemotherapy service of the PTC is reviewed under measures [09-7B-129](#) to [09-7B-162](#). All the chemotherapy facilities and staff and chemotherapy related activities which come under the measures are reviewed as one entity for the PTC. This entity is what is referred to as 'the chemotherapy service' for example there should be a single head of service for all chemotherapy for the PTC.

The chemotherapy measures refer to 'the chemotherapy service'. Prior to these measures and the peer review of children's cancer services, it may not have been conventional for the staff involved to consider themselves as part of such a defined entity as could be identified by a label like 'the chemotherapy service' - prescribing and administering chemotherapy were just part of the job as a whole. However, if definite quality measures are going to be applied in reality to the structures and processes involved in children's chemotherapy, then the compliance with these measures has to be verified 'on the ground' in relation to concrete existing practices. Thus a peer review visit has to relate to a recognised, declared set of people and facilities, with some boundary between them and whoever is going to be reviewed by a different visit. Also this allows for consistency of practice - for example, a set of practice guidelines are understood to apply across the whole of the defined service, which prevents groups of staff disagreeing over practice and asking to be peer reviewed separately.

In the case of children's chemotherapy, the service is also defined by the age boundary, with the provisions regarding flexibility, as stated in the introduction to the children's cancer measures.

In common with the rest of the Manual for Cancer Services, the responsibility for peer review purposes of every measure is attributed to some named person or other. For chemotherapy this person is termed the 'head of service', which again may be a somewhat new role for some organisations.

The same considerations apply to an oncology pharmacy service and the lead pharmacist.

Future revisions of the children's cancer chemotherapy measures may need to take into account any general changes in national guidance on chemotherapy which follow such reviews as the NCEPOD enquiry into chemotherapy and the reports of the NCAG.

Nomenclature.

The term "**chemotherapy**" refers to the use of those cytotoxic agents commonly understood and accepted as being covered by this term. The inclusion of certain other agents which may or may not be understood to fall clearly into this group is permissible for example biological therapies. The exact extent of the drugs to be included under the remit of the measures is a matter for local discretion unless otherwise stated in the measures themselves. It will largely be manifested by which regimens and which supportive drugs are named in the CCN lists and local lists of regimens.

For this set of measures, **systemic, intravenous, intramuscular, oral** and **subcutaneous** chemotherapy is included. Topical and intracavity chemotherapy is not included. The position regarding **intrathecal** chemotherapy is dealt with separately.

MEASURE DETAILS & DEMONSTRATION OF COMPLIANCE

In the measures, chemotherapy is referred to as being given over a complete period of treatment known as a **course**, which consists of giving the drugs over a repeated pattern known as a **cycle**. For entirely oral chemotherapy a cycle may be defined by the length of time in between mandatory reviews. The maximum intended number of cycles and therefore the intended length of the course may be pre-determined or **fixed**, or dependent on various factors and therefore **indeterminate or variable** from the outset. The separate occasions when drugs are given within a cycle are termed **administrations**. These are usually understood to refer to occasions of parenteral administration rather, than say, daily oral doses, oral treatment being referred to in the conventional way of pharmacological prescriptions.

None of the above terms, as used in these measures, are intended to have any other meanings or connotations other than those stated. Where a measure is intended to refer to a particular level of professional training or seniority it will be stated. If it is local practice to use different terms, meanings or connotations, this is not a matter for the measures or peer review.

The responsibility for review purposes for measures [09-7B-129](#) to [09-7B-130](#) lies with the head of service.

The head of service list of responsibilities

09-7B-129 The head of service should agree a list of responsibilities for the role with the lead cancer clinician of the trust involved in the chemotherapy service and the head of service's line manager.

Compliance: The list of responsibilities agreed by the lead cancer clinician and the line manager.

The PTC chemotherapy group

09-7B-130 There should be a chemotherapy group for the PTC with a membership to include those listed below and a named chair, drawn from the membership list:

- consultant paediatric oncologist
- nurse involved in the chemotherapy treatment of children
- designated pharmacist (see measure [09-7B-154](#))
- the head of service, if not included in the above.

Notes:

- *The chair would normally be the head of service.*
- *The members may or may not fulfil other roles in the PTC (for example lead nurse).*
- *The chemotherapy service may choose alternative names for this group, or it may be a subgroup of another - for instance, the host hospital's drug and therapeutics committee or the locality's cancer chemo group. This is not subject to review.*

The PTC chemotherapy group should have agreed terms of reference with the Drug and Therapeutics Committee of the trust hosting the chemotherapy service. The terms of reference should delegate responsibility to the chemotherapy group for:

- ensuring implementation of the chemotherapy measures across the service;
- ensuring implementation of NICE guidance on applicable chemotherapy agents across the service;
- liaising with the CCNCG and the network chemotherapy group of the host cancer network to ensure that the service's practice is consistent with the rest of the host cancer network and the CCN.

Compliance: The membership list with a named chair, agreed by the head of service.
The terms of reference, agreed by the chair of the PTC chemotherapy group and the chair of the trust's drug and therapeutics committee.

PTC chemotherapy group representative on the drugs and therapeutics committee

09-7B-131 At least one member from those listed specifically in measure [09-7B-130](#) should be a representative on the drug and therapeutics committee of the host trust of the PTC.

Note:

If the PTC group is contained within the trust's drug and therapeutics committee then this measure is automatically fulfilled.

Compliance: The membership of the trust's drug and therapeutics committee.

MEASURE DETAILS & DEMONSTRATION OF COMPLIANCE

PTC list of acceptable regimens

09-7B-132

The PTC chemotherapy group should agree the list of acceptable regimens for its service, with the CCNCG and the network chemotherapy group of the host cancer network of the PTC.

The service should agree the list (specified in measure [09-7A-130](#)) of regimens, parts of regimens, routes and settings which identify the permissible practice of nurses who have undergone only the CCN's low risk training programme in chemotherapy administration.

Note:

For compliance with measure [09-7A-130](#) the CCNCG should agree the list of regimens for the CCN across the PTC and all POSCUs and levels; and the PTC group, for compliance with this measure, should agree its service's list compatible with the list for the CCN.

Compliance: The PTC list (or updated, see below) for the year prior to the review visit or completed self assessment, as hard copy or on a computerised prescribing system agreed by the chair of the CCNCG and the chair of the PTC group.

For PTC groups meeting for two or more years since the publication of these measures the lists are needed from the first year, then the agreed updates for each subsequent complete year up to the peer review visit or completed self assessment.

Policy on unsafe chemotherapy workload

09-7B-133

The PTC chemotherapy group should, in consultation with the relevant hospital managers, agree a policy which specifies for each chemotherapy service in the CCN:

- who makes the decision that chemotherapy workload has reached unsafe levels;
- the process which is then followed.

Compliance: The policy agreed by the chair of the PTC chemotherapy group and the relevant hospital managers from the hospitals hosting the children's chemotherapy services in the CCN.

Policy for preventing regular use of regimens not on the agreed list

09-7B-134

The PTC chemotherapy group should agree a written policy with the CCNCG for preventing regular use of regimens not on the accepted list. The policy should state:

- the exceptional circumstances under which such a regimen could be used;
- the procedure which is then required to authorise it.

Note:

The CCNCG should produce the policy for its compliance with measure [09-7A-131](#) and the PTC chemotherapy group should agree to abide by it for its compliance with this measure.

Compliance: The written policy agreed by the chair of the CCNCG and the chair of the PTC group.

Record of the use of unlisted regimens

09-7B-135

The chemotherapy service should record, for review by the CCNCG, the instances of the use of a regimen which is not on the agreed list. They should record in each case:

- the regimen used;
- the indication for its use.

Compliance: The record of the use of regimens which are not on the agreed list.

MEASURE DETAILS & DEMONSTRATION OF COMPLIANCE

GUIDELINES/PROTOCOLS FOR HOSPITAL STAFF FOR THE PREVENTION AND TREATMENT OF THE COMPLICATIONS OF CHEMOTHERAPY (Measures [09-7B-136](#) to [09-7B-138](#))

Guidelines/protocols on pre-chemotherapy investigations

09-7B-136 There should be guidelines/protocols covering laboratory blood tests and other investigational parameters to be fulfilled prior to starting chemotherapy, before a whole course and before individual cycles, covering both generic parameters and those specific to the regimens on the service's agreed list.

Note:

It would be easy to make this measure impossible to comply with because of the open-ended range of possible parameters. Reviewers are required to exercise their discretion to judge whether this issue has been realistically addressed.

Compliance: The written guidelines/protocols agreed by the head of service.

Introduction

The term guidelines/protocols is used since some parts may be in the form of general advice (guidelines) and some may be in the form of precise instructions (protocols). They may form part of a wider ranging set of information. There may be different documents for solid tumour oncology than for haemato-oncology or there may be documents common to both. All these options are acceptable providing measures [09-7B-136](#) to [09-7B-138](#) are complied with. They should all be agreed by the head of service.

General chemotherapy guidelines/protocols

09-7B-137 There should be guidelines/protocols covering the following:

- cytotoxic administration techniques
- the care of those venous access devices used by the service, including the treatment of line complications
- the recognition and treatment of neutropenic sepsis
- the use of blood products
- the prevention and treatment of cytotoxic-induced emesis
- the recognition and treatment of cytotoxic extravasation
- the recognition and treatment of allergic reactions including anaphylaxis
- the prevention and treatment of stomatitis, other mucositis and diarrhoea.

Note:

Reviewers should check guidelines and protocols are appropriate for children's cancer.

Compliance: The written guidelines/protocols agreed by the head of service.

Regimen specific chemotherapy guidelines/protocols

09-7B-138 There should be guidelines/protocols for the treatment and/or prevention of regimen-specific complications not included in the above measure and relevant to the regimens on the service's agreed list of regimens.

Note:

The following are by way of illustration and may not all be applicable:

- *intravenous pre and post-hydration*
- *folinic acid rescue*
- *the use of MESNA*
- *the prevention of serious hypersensitivity reactions.*

Compliance: The written guidelines/protocols agreed by the head of service

Note:

It would be easy to make this measure impossible to comply with because of the open-ended range of possible complications and remedies. The reviewers are required to exercise their discretion to judge whether this issue has been realistically addressed.

MEASURE DETAILS & DEMONSTRATION OF COMPLIANCE

Information for patients and carers

09-7B-139 There should be common written information for the CCN for patients and carers covering the action they should take, whom they should contact for advice and the symptoms that should prompt this, with regards to the following complications of chemotherapy:

- neutropenic sepsis
- cytotoxic extravasation
- nausea and vomiting
- stomatitis, other mucositis and diarrhoea
- care of venous access device.

There should be common written information for the CCN for patients and carers covering information specific to the regimens on the service's agreed list, which has not been covered by the items above.

Notes:

- *It would be easy to make this measure impossible to comply with because of the open-ended range of possible information beyond the bulleted items. Reviewers are required to exercise their discretion to judge whether this issue has been realistically addressed.*
- *The existence of such written information is especially important, however, regarding oral cytotoxic drugs being taken by patients at home.*
- *Some other groups, for example social workers and research staff are not included as outside mandatory peer review requirements, being employed from outside the NHS in the majority of cases.*

Compliance: The written information.

It is recommended that it is available in languages and formats understandable by patients including local ethnic minorities and people with disabilities. This may necessitate the provision of visual and audio material.

Informed consent for chemotherapy

09-7B-140 The consent form, which patients or carers sign prior to starting a course of chemotherapy, should enable them to acknowledge that they have received the generic written information specified in measure [09-7B-139](#) and, if applicable, regimen-specific information. In the case of the regimen specific information, the regimen should be specified on the consent form.

Compliance: The consent form.

Notes:

It is recommended that the form is available in languages and formats understood by local ethnic minorities and people with disabilities.

For the purposes of peer review and for the relevant parts of the chemotherapy practice, consent forms provided as part of the entry process into multicentre clinical trials would be considered compliant.

RECORDING OF CHEMOTHERAPY TREATMENT (Measures [09-7B-141](#) to [09-7B-143](#))

Introduction

These measures address, for specified parts of the pathway, the content of the records, not who does the recording or where the records are kept or any other aspects of the use of the records. The same record contents should be available at PTC and POSCUs for a given patient who receives parts of their treatment at the PTC and at a POSCU.

Pre-course records

09-7B-141 There should be treatment records for each patient fulfilling the following minimum criteria prior to the start of a **course** of chemotherapy:

- patient identification
- weight, height, surface area

MEASURE DETAILS & DEMONSTRATION OF COMPLIANCE

- cancer type
- regimen and doses (including all cytotoxic chemotherapy drugs to be used and elective essential support drugs other than antiemetics); trial name or number if applicable
- route of administration (oral, IV, IV infusion, IM, SC)
- number of cycles intended
- frequency of cycles and of administrations within a cycle
- investigations necessary prior to starting the whole course
- investigations to be performed serially during the course (to detect/monitor both toxicity and response) and their intended frequency
- number of cycles
- planned attendances managed by agreed non-medical staff, for example nurse led attendances
- site of administration (PTC, POSCU, community).

Compliance: Reviewers should examine examples of patients' chemotherapy records or the computerised prescribing programme.

Pre-cycle records

09-7B-142

There should be treatment records for each patient fulfilling the following minimum criteria prior to each **cycle**:

- the results of essential serial investigations applicable to that cycle (and prior to an administration within a cycle, if applicable);
- any dose modifications and whether or not they are intended to be permanent;
- any cycle (or administration) delays;
- any introduced support drugs not recorded under measure [09-7B-141](#).

Compliance: Reviewers should examine examples of patients' chemotherapy records or computerised prescribing programme.

Post-course records

09-7B-143

There should be treatment records for each patient fulfilling the following minimum criteria **after the final cycle** is given in a course:

- whether the course was completed or not
- if not completed - the reasons for cessation
- for completed courses of treatment of measurable disease, a reference to the response should be included.

Compliance: Reviewers should examine examples of patients' chemotherapy records, or computerised prescribing programme.

Verification procedure

09-7B-144

There should be a verification procedure, which is carried out by the person about to administer, before each physical administration of chemotherapy to ensure that the following aspects are correct:

- patient's identification, as agreed with the patient on that occasion, on the prescription chart and on all labelled drugs
- critical test results
- regimen and individual drug identification
- diluents and dilution volumes, and any hydration
- that supportive drugs have been given as per prescription
- administration route and duration
- cycle number
- the administration, as per the schedule, within the cycle.

Compliance: The written procedure agreed by the head of service.
Reviewers should enquire of the local practice.

MEASURE DETAILS & DEMONSTRATION OF COMPLIANCE

Out of hours chemotherapy policy

- 09-7B-145** There should be a policy for the chemotherapy service, agreed with the supporting oncology pharmacy service(s) and the relevant hospital manager(s), stating:
- in which, and only which, exceptional circumstances the initiation of an administration of chemotherapy may be allowed outside "normal working hours";
 - the arrangements for administering chemotherapy which then apply.

Notes:

- *The exact definition of "normal working hours" should be agreed locally as part of the policy.*

It is widely accepted and strongly recommended that chemotherapy should, as far as possible, take place during normal working hours. It is more practical, however, from the point of view of a precise review measure, to define and agree the few exceptions to this rule.

Compliance: The policy agreed by the head of service, the lead pharmacist(s) of the supporting oncology service(s) and the relevant hospital manager(s).

TRAINING FOR STAFF ADMINISTERING CHEMOTHERAPY (Measures 09-7B-146 to 09-7B-151)

Chemotherapy nurse trainer

- 09-7B-146** There should be a named chemotherapy nurse for the clinical chemotherapy service with responsibility for training in chemotherapy administration.

The nurse should be qualified to 20 credits at first degree level in paediatric oncology including one module or more in chemotherapy administration (external training) and: the nurse should be currently administering chemotherapy for part of the time, with a minimum of two years previous experience in chemotherapy administration.

The named nurse trainer should:

- have an agreed list of responsibilities which should include:
 - i) choosing nurses who are initially judged able to act as assessors of competence in chemotherapy administration;

Notes:

This responsibility applies only to the first round of peer review against these measures. Once the CCN training programme is established and reviewed it is intended that assessors appointed subsequently would be qualified according to these measures.

- ii) ensuring that staff administering chemotherapy in the service are trained and assessed for competence according to the competencies specified in the introduction or have met the exemption requirements as specified in the introduction;

- have an agreed minimum time allowed for those responsibilities in their weekly timetable.

Notes:

- *The named nurse may have had two years' experience of chemotherapy administration partially or wholly in another clinical chemotherapy service of the CCN or (with the CCNCG chair's agreement) in another CCN.*
- *The service under review may name more than one nurse trainer, or may share the trainer with one or more POSCUs.*

Compliance: The named nurse agreed by the head of service of the chemotherapy service under review.

Confirmation of completion of study.

The start date in chemotherapy administration.

The list of responsibilities and the portion of time agreed by the head of service.

MEASURE DETAILS & DEMONSTRATION OF COMPLIANCE

Introduction

The CCNCG should agree a nurse training programme in chemotherapy administration using the RCN competencies with special modifications for partial training for low risk treatments and for medical staff administering chemotherapy.

There should be a named experienced and trained chemotherapy nurse for each chemotherapy service who should be responsible for training and assessing the competencies of staff. Each chemotherapy service should maintain a list of those staff who are competent and authorised to administer chemotherapy. There are exemptions at first for those who are already trained and experienced. (See the introduction to the children's cancer measures).

It takes time to implement this, so the significance of a service's failure to have only authorised staff administering chemotherapy increases with the run up time available to them before the service's peer review. Lack of compliance should be a matter for discussion between the zonal peer review co-ordinating team and the relevant SHA.

The measures in this section should be applied to each chemotherapy service.

List of staff authorised to administer chemotherapy (nursing)

09-7B-147 The service should maintain a list of named nursing staff who have been assessed as competent to administer chemotherapy unsupervised, having met the competencies specified in the introduction. The list should separately identify those having received low risk training as competent to administer the selected treatments identified in measure [09-7A-136](#).

Note:

See the measure below for inclusion of medical staff on the list.

Compliance: The list of authorised staff agreed by the head of service.
The reviewers should enquire of the working practice of the service in relation to conditions allowing inclusion on the list.

Administration/authorisation policy

09-7B-148 The service should agree a policy to the effect that chemotherapy administration staff who are not authorised on the list as defined in measure [09-7B-147](#) may administer chemotherapy only as part of their training and assessment and in the presence of authorised staff.

Compliance: The policy agreed by the head of service.
The reviewers should enquire as to the working practices of the department.

Provision of training

09-7B-149 The service should agree to provide the CCN's agreed training programme for its staff, including the agreed part of the programme for medical staff and the low risk training programme.

Compliance: The programme summary agreed by the chair of the CCNCG and the head of service.

List of staff authorised to administer chemotherapy (medical)

09-7B-150 There should be a list, for the chemotherapy service of medical staff authorised to administer chemotherapy. The service should include the following, and only the following, medical staff on the list of those authorised to administer chemotherapy:

- those who have been trained and reviewed according to the CCN's agreed programme for medical staff (measure [09-7A-135](#));
- those who have received training according to the previous Manual of Cancer Services Measures (2004);
- those in post administering chemotherapy for two or more years prior to the publication of these measures.

Note:

The service may wish to offer training to the latter category of staff and may wish to make this a pre-condition for their inclusion on the list.

MEASURE DETAILS & DEMONSTRATION OF COMPLIANCE

Compliance: The list agreed by the head of service.
The reviewers should enquire of the working practice of the service in relation to conditions allowing inclusion on the list.

Prescribing policy

09-7B-151

The service should agree a prescribing policy to the effect that:

- the decision to treat with a course of chemotherapy and the choice of a particular regimen should only be taken by a consultant paediatric oncologist;
- the prescribing of the first cycle of a course of that previously chosen regimen should be done by a consultant paediatric oncologist or specialist NCCG in paediatric oncology or specialist trainee at ST3 level or above.

The policy should be distributed to consultants using the service, medical staff working on their firms or treating their patients oncologically, lead pharmacist(s) and lead nurse(s) associated with the service.

Compliance: The policy agreed by the head of service
The reviewers should enquire as to the distribution process.

Notes:

Parts of the compliance evidence may be provided by the security password system of a computerised prescribing system.

Minor short falls in the completeness of the distribution should not preclude compliance with this measure.

PTC ONCOLOGY PHARMACY SERVICES (Measures [09-7B-152](#) to [09-7B-162](#))

Introduction

The chemotherapy service in the PTC or in a POSCU may receive its pharmacy support from a pharmacy which has previously been reviewed as part of the peer review of "adult" cancer services.

If, at such a previous review, there was compliance with the measures regarding preparation facilities and COSHH they will be regarded as compliant for the review of children's cancer services provided it is within the timeframes stated in those measures.

The remaining oncology pharmacy measures should be applied specifically and separately with regards to the children's service.

The responsibility for review purposes for these measures lies with the lead pharmacist.

List of responsibilities for the lead pharmacist

09-7B-152

The lead pharmacist should agree a list of responsibilities for the role with the lead cancer clinician(s) of the trust(s) involved in the service and the lead pharmacist's line manager.

Note:

See the notes below for the case where the lead pharmacist is the only designated pharmacist for the service

Compliance: The list of responsibilities agreed by the lead cancer clinician(s) and the line manager.

DESIGNATED PHARMACISTS (Measures [09-7B-153](#) to [09-7B-157](#))

Introduction

The duties identified in measures [09-7B-154](#) and [09-7B-155](#) may be divided between more than one designated pharmacist. They need not be their only duties. The duties in measure [09-7B-156](#) should be assigned to a single designated pharmacist. Where the oncology pharmacy service under review has only one pharmacist they should take the role of designated pharmacist as well as lead pharmacist and should have all the duties of measures [09-7B-153](#) to [09-7B-157](#) in their list of responsibilities.

Designated pharmacists for the service

09-7B-153

There should be one or more named pharmacists for the service whose role is defined by the duties described in measure [09-7B-154](#) below. For review purposes these pharmacists are termed "designated pharmacists" .

Note:

MEASURE DETAILS & DEMONSTRATION OF COMPLIANCE

The role of designated oncology pharmacist need not occupy the whole of a pharmacist's duties.

Compliance: The named designated pharmacist(s) agreed by the lead pharmacist.

List of responsibilities for the designated pharmacist

09-7B-154 The following duties should be included in the list of responsibilities of a designated pharmacist agreed by the lead pharmacist and the relevant line manager for the children's chemotherapy services, declared as being supported by the pharmacy service under review:

- liaison with and advice to POSCU pharmacists
- overall responsibility for oncology services to the named wards/areas/outpatient facilities used exclusively or preferentially for chemotherapy and clean procedures
- overall responsibility for oncology services to the outpatient services on the days they are used for chemotherapy
- overall responsibility for cytotoxic chemotherapy.

Compliance: The list of responsibilities of the relevant named designated pharmacist(s) agreed by the lead pharmacist and the relevant line manager.

Responsibility for the preparation facilities

09-7B-155 The following duty should be included in the list of responsibilities of a single designated pharmacist:

- overall responsibility for the clean chemotherapy preparation facilities of the pharmacy service.

Note:

This could instead be on the list of responsibilities of a designated pharmacist of an adult oncology pharmacy service.

Compliance: The list of responsibilities of the relevant named designated pharmacist agreed by the lead pharmacist and the relevant line manager.

Pharmaceutical responsibility for chemotherapy related research

09-7B-156 The following duty should be included in the list of responsibilities of a designated pharmacist:

- liaison over pharmaceutical matters with investigators carrying out clinical trials and/or other clinical research involving the drug treatment of malignant diseases.

Note:

These are investigators working in the children's chemotherapy services supported by the pharmacy service under review.

Compliance: The list of responsibilities of the relevant named designated pharmacist(s) agreed by the lead pharmacist and the relevant line manager.

Pharmacy department organisational chart

09-7B-157 The managerial relationship of the lead pharmacist and, if applicable, the designated pharmacists to the rest of the pharmacy department of the hospital hosting the oncology pharmacy service, should be defined by an organisational chart.

Note:

When a specialist hospital has a pharmacy dealing entirely in oncology this measure should be discussed specifically with reviewers.

Compliance: The organisational chart agreed by the lead pharmacist and the head of the hospital pharmacy department.

MEASURE DETAILS & DEMONSTRATION OF COMPLIANCE

PREPARATION FACILITIES (Measures [09-7B-158](#) to [09-7B-159](#))

External pharmacy audit

09-7B-158 The oncology pharmacy service should have been independently audited for at least the clean preparation of compounds and the preparation of chemotherapy, and should have agreed to abide by its findings.

The audit should be conducted as follows:

- licensed units - Medicines and Healthcare Products Regulatory Agency inspection within two years prior to the peer review visit or completed self assessment;
- unlicensed units - an external audit by the Regional Quality Assurance Pharmacist within eighteen months prior to the peer review visit or completed self assessment.

Compliance: The results of the inspection or external audit agreed by the lead pharmacist.

Outcome of the external pharmacy audit

09-7B-159 If the inspection/audit identified in the previous measures requires any matters to be dealt with there should be remedial actions agreed for this. Any resulting proposals for investment should have been presented to the head(s) of the pharmacy department(s) of the host hospital(s) and to the relevant locality group.

Compliance: The remedial actions agreed by the lead pharmacist.
The reviewers should enquire if there were any investment proposals and if they have been presented to the head(s) of pharmacy and the locality groups.

PRESCRIBING SAFEGUARDS (Measures [09-7B-160](#) and [09-7B-161](#))

Prescriptions checked and authorised by a pharmacist

09-7B-160 All cytotoxic chemotherapy prescriptions should be checked and authorised by a pharmacist.

Compliance: Reviewers should spot check prescriptions and/or examine the relevant computerised prescribing software security system.

Computer generated prescriptions

09-7B-161 All prescriptions of cytotoxic chemotherapy agents should be computer-generated at least when using regimens from the agreed list.

Compliance: The reviewers should enquire of the working practice of the service and see examples of the prescriptions.

COSHH service review

09-7B-162 The lead pharmacist and an authorised COSHH advisor should have met to review the service against the current COSHH regulations. Any recommendations and/or results of the review should have been made known to the lead manager responsible for risk management in the host NHS trust.

Compliance: The minutes of the meeting and a written submission to the trust risk manager, both agreed by the head of service and having taken place within the year preceding the peer review visit or completed self assessment.

PTC RADIOTHERAPY MEASURES (Measures [09-7B-163](#) to [09-7B-168](#))

The responsibility for review purposes for the PTC radiotherapy measures lies with the head of service of the department of radiotherapy, identified as the department for radical children's treatments for the CCN, in topic [7A](#). This department should be reviewed against these measures.

Lead therapeutic radiographer and list of responsibilities

09-7B-163 The department should have a lead therapeutic radiographer for children, who has specified time for the role in their job plan or timetable and an agreed list of responsibilities for the role.

MEASURE DETAILS & DEMONSTRATION OF COMPLIANCE

Notes:

See [appendix 1](#) for an illustration of the responsibilities of the role.

Compliance: The named radiographer, the specified time and the list of responsibilities agreed by the head of service.

Specified anaesthetist's time for radiotherapy

09-7B-164 The responsibility for anaesthetising children for radiotherapy in the department should be included in the responsibilities for which DCC PA time is specified in the job plan of a named consultant paediatric anaesthetist or anaesthetists.

Note:

The **amount** of time is not subject to review.

Compliance: The named paediatric anaesthetist(s) and the job plan(s), agreed by the head of service and the anaesthetist's clinical director.

Note:

The 'as required' nature of this work means that a regular time of the week cannot always be assigned to this on the job plan.

Specified ODP's time for radiotherapy

09-7B-165 Specified time for the role of ODP for children's radiotherapy in the department should be included in the job description of a name paediatric ODP or ODPs.

Note:

The **amount** of time is not subject to review.

Compliance: The job description of the named ODP(s) agreed by the head of service and the relevant hospital manager. Note: The 'as required' nature of this work means that a regular time of the week cannot always be assigned to this on the job description.

Specified recovery nurse's time for radiotherapy

09-7B-166 Specified time for the role of paediatric recovery nurse for children's radiotherapy in the department should be included in the job description of a named paediatric recovery nurse or nurses.

Note:

The **amount** of time is not subject to review.

Compliance: The job description of the named nurse(s) agreed by the head of service and the relevant hospital manager.

Note:

The 'as required' nature of this work means that a regular time of the week cannot always be assigned to this on the job description.

Radiotherapy recovery room

09-7B-167 The department should have a recovery room with paediatric resuscitation equipment, the room being reserved exclusively for this use when children are receiving radiotherapy under sedation or anaesthetic, in the department.

The room should be within or adjacent to the radiotherapy department.

Compliance: The reviewers should view the facilities and enquire as to the working practices of the department.

Specified play specialist's time for radiotherapy

09-7B-168 Specified time for the role of play specialist for children's radiotherapy in the department should be included in the job description of a named play specialist or specialists.

Note:

The **amount** of time is not subject to review.

MEASURE DETAILS & DEMONSTRATION OF COMPLIANCE

Compliance: The job description of the named play specialist(s) agreed by the head of service and the relevant hospital manager.

Note:
The 'as required' nature of this work means that a regular time of the week cannot always be assigned to this on the job description.

SURGICAL MEASURES (Measures [09-7B-169](#) to [09-7B-172](#))

Designated specialist paediatric surgeons for children's cancer

09-7B-169 There should be at least two accredited specialist paediatric surgeons with DCC PAs contracted to the host hospital(s) of the PTC designated for operating lists, inpatient care and outpatient clinics in paediatric surgical oncology.

- At least one should be named as a surgical core member of the PTC diagnostic and treatment MDT.
- Their work plans should specify joint outpatient consultations and joint inpatient consultations with non-surgical core members of the MDT as part of their responsibilities.
- At least one should be a member of the CCLG.

Note:

Where there is a range of specialist MDTs for the PTC the MDT, which this measure then refers to, is the MDT dealing with children's solid tumours other than CNS malignancies (this MDT may **include** CNS tumours as well).

Compliance: The named surgeons with their specialist registration.
The work plans.
The MDT core membership.

Note:

The actual number of DCC PAs is not subject to review.

Specified paediatric anaesthetist's sessions for children's cancer surgery

09-7B-170 There should be DCC PAs contracted by consultant paediatric anaesthetists in the host hospital(s) of the PTC designated for children's cancer diagnostic and interventional radiology and surgical procedures.

Compliance: The named anaesthetists.
The work plans.

Note:

The actual number of anaesthetists and/or DCC PAs is not subject to review.

Specified paediatric ODP's sessions for children's cancer surgery

09-7B-171 There should be sessions of paediatric ODP time specified for children's cancer diagnostic and interventional radiology and surgical procedures in the host hospital(s) of the PTC.

Compliance: The timetable showing the specified sessions agreed by the lead clinician of the PTC and the relevant hospital manager.

Note:

The actual number of sessions is not subject to review.

Weekly scheduled theatre lists for children's cancer interventional radiology or surgical procedures

09-7B-172 There should be weekly scheduled theatre list(s) in the host hospital(s) of the PTC, governed by a policy which specifies that those lists are to be used for children's cancer interventional radiology or surgical procedures in preference to any other procedures.

Compliance: The operating theatre timetable showing the specified list(s).
The policy agreed by the lead clinician of the PTC and the relevant hospital manager.

Note:

The actual number of lists is not subject to review.

TOPIC 09-7B-2 - PTC, LATE EFFECTS MDT MEASURES

When is a Team a Team and when is it not a Team?

The measures review a variety of aspects of the team, both structure and function, but the key question which underlies all this is who exactly constitutes the MDT from the point of view of the peer review? Which group of people should be put forward for review against these measures and who is it who is held compliant or not compliant?

This is best answered from the patient's point of view. If you were a patient, who would you consider to be your MDT?

Primarily it is that group of people of different health care disciplines which meets together at a given time (whether physically in one place, or by video or tele-conferencing) to discuss a given patient and who are each able to contribute independently to the decisions about the patient. They constitute that patient's MDT.

The way the MDT meeting itself is organised is left to local discretion such that different professional disciplines may make their contributions at different times, without necessarily being present for the whole meeting, in order to prevent wastage of staff time. The key requirement is that each discipline is able to contribute independently to the decisions regarding each relevant patient.

MEASURE DETAILS & DEMONSTRATION OF COMPLIANCE

PTC FACILITIES MEASURES (Measures [09-7B-201](#) to [09-7B-208](#))

Lead clinician and responsibilities

09-7B-201

There should be a single lead clinician for the PTC late effects MDT who should then be a core member.

The lead clinician of the MDT should have agreed the responsibilities of the position with the cancer lead clinician of the host trust.

Note:

The role of lead clinician of the MDT should not of itself imply chronological seniority, superior clinical experience or superior clinical ability.

Compliance: The named lead clinician for the PTC late effects MDT agreed by the cancer lead clinician of the host trust.

The responsibilities agreed by the lead clinician of the MDT and the lead clinician of the host trust.

Note:

See appendix 1 for an illustration of the responsibilities of this role.

Core team membership

09-7B-202

The MDT should provide the names of the core team members for named roles in the team.

The core team specific to the PTC late effects MDT should include:

- an oncologist with specific DCC PAs in their job plan, dedicated to the work of the late effects MDT;

Note:

The oncologist may be a paediatric or adult oncologist, clinical oncologist, medical oncologist or haemato-oncologist.

- specialist nurse;

Note:

The specialist nurse is recommended to be compliant with the minimum core MDT nurse measures of an MDT. The particular MDT type is not specified and although recommended this is not a requirement for compliance with this measure.

- endocrinologist;
- an NHS employed member of the core or extended team should be nominated as having specific responsibility for users' issues and information for patients and carers;

MEASURE DETAILS & DEMONSTRATION OF COMPLIANCE

- a member of the core team should be nominated as the person responsible for ensuring that recruitment into clinical trials and other well designed studies is integrated into the function of the MDT;
- MDT co-ordinator/secretary.

Notes:

- *Where a medical speciality is referred to the core team member should be a consultant. The cover for this member need not be a consultant but should be at a minimum seniority of staff grade or specialist registrar (ST3).*
- *The co-ordinator/secretary role needs different amounts of time depending on team workload, see appendix 1 for an illustration of the responsibilities of this role.*
- *The co-ordinator and secretarial role may be filled by two different named individuals or the same one. It need not occupy the whole of an individual's job description.*
- *There may be additional core members agreed for the team besides those listed above.*

Compliance: Name of each core team member with their role, agreed by the lead clinician of the MDT.

Notes:

The reviewers should record in their assessment each case where the post(s) needed to provide the minimum core membership, for a given listed role in the measure, is unfilled or non-existent or existing posts cannot provide the service. This does not refer to mere holiday or sickness absence, or less than two thirds attendance and it refers only to the core member roles listed in the measure, not to additional roles that the MDT has decided locally to include as core members. The reviewers should identify the particular missing roles and identify the particular MDT in the report.

Extended team membership

09-7B-203

The MDT should provide the names of members of the extended team for named roles in the team. If they have not been specified already as core members the extended team for late effects should include:

- person agreed as representing allied health professionals;
- person agreed as representing psychological services;
- consultant specialist in reproductive medicine;
- consultant oncologist with adult practice.

Note:

There may be additional members agreed for the extended team besides those listed above.

Compliance: Name of each extended team member.

MDT MEETINGS (Measures [09-7B-204](#) to [09-7B-206](#))

Treatment planning meeting

09-7B-204

The MDT should meet at an agreed frequency, record core members attendance and have a written procedure governing how to deal with referrals which need a decision before the next scheduled meeting (guidance only - for example letters or phone calls between specified members, retrospective discussion at the next scheduled meeting).

Compliance: Attendance records of the meeting.

Written procedure agreed by the lead clinician of the MDT.

Cover arrangements for core team members

09-7B-205

The MDT should agree cover arrangements for each core member.

Notes:

- *This refers to the nominating of staff that should in general be expected to provide cover for core members, for example a SpR on a consultant's team or core members of the same discipline providing cover for each other. It does not refer to the member having to provide a person to cover for each and every absence. This*

MEASURE DETAILS & DEMONSTRATION OF COMPLIANCE

aspect is dealt with by the attendance measure below.

- *Where a medical specialty is referred to the cover for a core member need not be a consultant, but should be at a minimum seniority of specialist registrar or staff grade.*

Compliance: Written arrangements agreed by the lead clinician of the MDT.

Core members attendance

09-7B-206 Core members or their arranged cover (see measure [09-7B-205](#)) should attend at least two thirds of the number of meetings.

Compliance: Attendance record of the MDT. Note: The intention is that core members of the team should be personally committed to it, reflected in their personal attendance at a substantial proportion of meetings not relying instead on their cover arrangements. Reviewers should use their judgement on this matter and should highlight in their report where this commitment is lacking.

OPERATIONAL POLICIES (measures [09-7B-207](#) and [09-7B-208](#))

Operational policy meeting

09-7B-207 Besides the regular meetings to discuss individual patients the team should meet at least annually to discuss, review, agree and record at least some operational policies.

Compliance: Minutes of at least one meeting agreed by the lead clinician of the MDT to illustrate the recording of at least some operational policies.

Key worker policy

09-7B-208 There should be an operational policy whereby a single named key worker for the patient's care at a given time is identified by the MDT for each individual patient and the name and contact number of the current key worker is recorded in the patient's case notes. The responsibility for ensuring that the key worker is identified should be that of the nurse MDT member(s).

The above policy should have been implemented for patients who came under the MDT's care after publication of these measures and who were under their care at the time of the peer review visit or completed self assessment.

Notes:

- *For information: according to the NICE palliative care guidance a key worker is a person who, with the patient's consent and agreement, takes a key role in co-ordinating the patient's care and promoting continuity, for example ensuring the patient knows who to access for information and advice.*
- *It may be appropriate for a paediatric oncology outreach nurse to be the key worker.*
- *It may be necessary to agree a different key worker for different parts of the patient's pathway. It is intended that at any one time a patient only has one named key worker.*

This is not intended to have the same connotation as the key worker in social work. It may be necessary to agree a single key worker across both a cancer site specific MDT and the specialist palliative care MDT for certain patients

Compliance: The written policy agreed by the lead clinician of the MDT. Reviewers should spot check some of the relevant patients' case notes.

MEASURE DETAILS & DEMONSTRATION OF COMPLIANCE

FUNCTIONS OF THE TEAM (Measures [09-7B-209](#) to [09-7B-214](#))

PROVIDING PATIENT CENTRED CARE (MEASURES [09-7B-209](#) TO [09-7B-212](#))

Patients' permanent consultation record

09-7B-209 The MDT should be offering patients the opportunity of a permanent record or summary of at least a consultation with the patient at which the arrangements for follow up options of their diagnosis and/or treatment options of any late effects were discussed.

Note:

The MDT may, in addition, offer a permanent record of consultations undertaken at other stages of the patient journey.

Compliance: The reviewers should enquire of the working practice of the team and see anonymised examples of records given to patients.

Note:

It is recommended that they are available in languages and formats understandable by patients, including local ethnic minorities and people with disabilities. This may necessitate the provision of visual and audio material.

Patient experience exercise

09-7B-210 The MDT should have undertaken or be undertaking an exercise during the previous two years prior to review or self assessment to obtain feedback on patients' experience of the services offered by the team.

The exercise should at least ascertain whether patients were offered:

- a key worker;
- the MDT's information for patients and carers (written or otherwise) - see measure [09-7B-212](#);
- the opportunity of a permanent record or summary of a consultation at which their treatment options were discussed.

Notes:

- *The exercise may consist of a survey, questionnaire, focus group or other method.*
- *There may be additional items in the exercise. It is recommended that other aspects of patient experience are covered.*

Compliance: The results (complete or in progress) of the exercise.

Outcome of patients' experience exercise

09-7B-211 Exercises in [09-7B-210](#) having been completed, the team should have presented and discussed its results at an MDT meeting and the team should have implemented at least one action point arising from the exercise.

Compliance: The results of the exercise.
A report of the action taken.

Provision of written patient information

09-7B-212 The MDT should provide written material for patients and carers which includes:

- information specific to that MDT about local provision of the services offering the treatment for the late effects of cancer treatment of children;
- information about patient involvement groups and patient self-help groups;
- information about the services offering psychological, social and spiritual/cultural support, if available;
- information specific to the late effects of children's cancer treatment (including names and functions/roles of the team members treating them).

Compliance: The written (visual and audio if used - see note below) material.

Note:

It is recommended that it is available in languages and formats understandable by

MEASURE DETAILS & DEMONSTRATION OF COMPLIANCE

*patients including local ethnic minorities and people with disabilities.
This may necessitate the provision of visual and audio material.*

Follow up and care planning decision

09-7B-213 The core MDT at their regular meeting should agree individual patient's follow up and care plans. A record should be made of the care plan. The record should include:

- the identity of the patient and their original disease and treatment;
- their late effects of treatment which have been diagnosed;
- the interventions needed (endocrinological, oncological, psychological, rehabilitation or a combination of these, or other interventions);
- the late effects for which they are particularly at risk in the future and the resulting surveillance methods needed; these should include psychological and social as well as physical late effects.

Compliance: Examples of the record of a meeting.

Notes:

Only exactly what is required in the list above is necessary for evidence. Detailed minutes of the content of discussions over patients are not required for evidence. For the purposes of evidence for peer review patient specific information should be anonymised.

It is recommended that this essential information is recorded on an MDT decision proforma as well as in individual patient's notes.

Late effects MDT follow up and long term sequelae protocol

09-7B-214 The PTC late effects MDT should agree their role as specified in the follow up and long term sequelae protocol of the CCN.

Note:

The follow up and long term sequelae protocol for the CCN constitutes, in effect, the late effects referral guidelines for the various types of MDT, governing which patients should be referred to the PTC late effects MDT.

Compliance: The protocol agreed by the lead clinician of the PTC late effects MDT.

Note:

The CCNCG for compliance with their relevant measure should produce the protocol and the MDT, for compliance with this measure, should agree to abide by it.

TOPIC 09-7B-3/4/5 - PTC, DIAGNOSTIC AND TREATMENT MDT MEASURES

NOTE: Where a PTC has more than one PTC D and T MDT then the second and third MDT should be review in the duplicate measures [09-7B-4](#) and [09-7C-5](#).

When is a Team a Team and when is it not a Team?

The measures review a variety of aspects of the team, both structure and function, but the key question which underlies all this is who exactly constitutes the MDT from the point of view of the peer review? Which group of people should be put forward for review against these measures and who is it who is held compliant or not compliant?

This is best answered from the patient's point of view. If you were a patient who would you consider to be your MDT?

Primarily it is that group of people of different health care disciplines, which meets together at a given time (whether physically in one place, or by video or tele-conferencing) to discuss a given patient and who are each able to contribute independently to the diagnostic and treatment decisions about the patient. They constitute that patient's MDT.

The way the MDT meeting itself is organised is left to local discretion such that different professional disciplines may make their contributions at different times, without necessarily being present for the whole meeting in order to prevent wastage of staff time. The key requirement is that each discipline is able to contribute independently to the decisions regarding each relevant patient. The specific situation where a separate "diagnostic" meeting of a particular subset of the MDT membership filters out cases with benign conditions is dealt with, where relevant, by a specific measure. For some cancer types the IOG had laid down detailed requirements over how the diagnostic process should be incorporated into the MDT system and this has also been translated into the measures where applicable.

Each diagnostic and treatment MDT in the PTC should be put forward for review against the measures in this section.

MEASURE DETAILS & DEMONSTRATION OF COMPLIANCE

Introduction

The responsibility for review purposes, for measure [09-7B-301](#) lies with the cancer lead clinician of the PTC host trust (see topic [09-1A](#)).

Lead clinician and responsibilities

09-7B-301

There should be a single lead clinician for the MDT who should then be a core member.

Note:

The MDT lead clinician is likely to be the lead clinician of the PTC, but need not necessarily be so.

The lead clinician of the MDT should have agreed the responsibilities of the position with the cancer lead clinician of the host trust.

Note:

The role of lead clinician of the MDT should not of itself imply chronological seniority, superior clinical experience or superior clinical ability.

Compliance: The named lead clinician for the MDT agreed by the cancer lead clinician of the host trust. The responsibilities agreed by the lead clinician of the MDT and the lead clinician of the host trust.

Note:

See [appendix 1](#) for an illustration of the responsibilities of this role.

MEASURE DETAILS & DEMONSTRATION OF COMPLIANCE

The responsibility for review purposes for the subsequent measures lies with the lead clinician of the MDT.

Core team membership

09-7B-302

The MDT should provide the names of the core team members for named roles in the team relevant to its team type as follows:

The core team common to all PTC D and T MDTs should include:

- specialist nurse; a separate person and role from the nurses specified below;
Note:
This nurse (not the ones specified below) should be put forward for review against the MDT nurse measures [09-7B-313](#) to [09-7B-315](#).
- nurse from the oncology ward nursing establishment allocated to the operational oncology beds;
- nurse from the PTC children's cancer day care facility;
- oncology pharmacist, from the designated pharmacists of the oncology pharmacy service supporting the PTC's chemotherapy service;
- an NHS- employed member of the core or extended team should be nominated as having specific responsibility for users' and carers' issues and information;
- a member of the core team should be nominated as the person responsible for ensuring that recruitment into clinical trials and other well designed studies is integrated into the function of the MDT;
- MDT co-ordinator and secretary.

In addition, the following should be included:

- 1) For a Single PTC D and T MDT for the CCN:
 - 2 paediatric oncologists with responsibility for solid tumours
 - 2 paediatric oncologists with responsibility for haematological malignancy
 - 2 clinical oncologists with responsibility for paediatric radiotherapy
 - radiologist
 - histopathologist
 - cytogeneticist
 - paediatric surgeon
 - *neurosurgeon
 - *neuropathologist
 - *neuroradiologist
 - *neurologist.
- 2) For a PTC D and T MDT dealing only with cases of haematological malignancy for the CCN:
 - 2 paediatric oncologists with responsibility for haematological malignancy
 - 2 clinical oncologists with responsibility for paediatric radiotherapy
 - histopathologist
 - cytogeneticist.
- 3) For a PTC D and T MDT dealing only with non-CNS solid tumours for the CCN:
 - 2 paediatric oncologists with responsibility for solid tumours
 - 2 clinical oncologists with responsibility for paediatric radiotherapy
 - radiologist
 - histopathologist
 - paediatric surgeon.
- 4) For a PTC D and T MDT dealing only with children's CNS malignancy for the CCN:
 - 2 paediatric oncologists with responsibility for CNS malignancy
 - 2 clinical oncologists with responsibility for paediatric CNS radiotherapy
 - neurosurgeon
 - neuropathologist
 - neuroradiologist
 - neurologist.

Notes:

- *For other team types (for example teams dealing with the residual practice left when there are one or more specialist PTC, MDTs) the list of core members needed in*

MEASURE DETAILS & DEMONSTRATION OF COMPLIANCE

addition to the common core members may be constructed by omitting just the irrelevant specialist members of the specialist MDTs, from list 1 above.

For example, for non-CNS teams, omit neurosurgeon, neuroradiologist, neuropathologist, neurologist.

For non-haemato-oncology teams, omit paediatric oncologist with responsibility for haemato-oncology and cytogeneticist.

*Where teams don't deal exclusively with CNS tumours, but deal with them as part of a wider range, the specialist CNS disciplines should not be subject to the attendance measures but should attend when a CNS case is being considered for treatment planning. For CNS only MDTs, they should be subject to the attendance measures.

- Where a medical speciality is referred to the core team member should be a consultant. The cover for this member need not be a consultant.
- The co-ordinator/secretary roles need different amounts of time depending on team workload, see appendix 1 for an illustration of the responsibilities of this role. The co-ordinator and secretarial role may be filled by two different named individuals or the same one. It need not occupy the whole of an individual's job description.
- There may be additional core members agreed for the team besides those listed above.
- As well as specified time for MDT attendance, in the DCC PAs of their job plan, consultant specialists other than paediatric oncologists should have the care of children with cancer included amongst the responsibilities for which DCC PA time is specified. The actual amount of time is not subject to review and the 'as required' nature of some of this work means that the time cannot always be scheduled into a regular part of the timetable. This note does not apply to paediatric oncologists, as it is expected that all, or the vast majority of their job plans, DCC PAs would be devoted to the care of children with cancer.

Compliance: Name of each core team member with their role, agreed by the lead clinician of the MDT. The job plans of the relevant specialists.

Note:

The reviewers should record in their assessment each case where the post(s) needed to provide the minimum core membership for a given listed role in the measure is unfilled or non-existent or existing posts cannot provide the service. This does not refer to mere holiday or sickness absence, or less than two thirds attendance, and it refers only to the core member roles listed in the measure, not to additional roles that the MDT has decided locally to include as core members. The reviewers should identify the particular missing roles and identify the particular MDT in the report.

EXTENDED TEAM MEMBERSHIP

Note:

There is no measure in this section covering the minimum extended team membership of the PTC diagnostic and treatment planning MDT. Instead, the staffing levels of the disciplines involved have been related to the patient throughput of the PTC and a measure has been incorporated into the PTC core measures ([09-7B-125](#)).

MDT MEETINGS (measures [09-7B-303](#) to [09-7B-305](#))

Treatment planning meeting

09-7B-303

A single diagnostic and treatment MDT for a whole PTC should meet weekly, record core members' attendance and have a written procedure governing how to deal with referrals which need a decision before the next scheduled meeting (guidance only - for example letters, emails or phone calls between certain specified members, retrospective discussion at next scheduled meeting).

Note:

Other configurations of diagnostic and treatment MDTs should meet at agreed frequencies and each MDT comply with the rest of this measure.

MEASURE DETAILS & DEMONSTRATION OF COMPLIANCE

Compliance: Attendance records of the meetings.
Written procedure agreed by the lead clinician of the MDT.
The frequency of meeting agreed by the lead clinician of the PTC.

Cover arrangements for core members

09-7B-304 The MDT should agree cover arrangements for each core member.

Notes:

- *This refers to the nominating of staff that should in general be expected to provide cover for core members, for example a SpR on a consultant's team or core members of the same discipline providing cover for each other. It does not refer to the member having to provide a person to cover for each and every absence. This aspect is dealt with by the attendance measure below.*
- *Where a medical specialty is referred to the cover for a core member need not be a consultant, but should be at a minimum seniority of specialist registrar ST3 or staff grade.*
- *Core members should arrange cover only from within the discipline of the core member type as listed in measure [09-7B-302](#) for example paediatric surgeon for paediatric surgeon, nurse specialist for nurse specialist. The exceptions, for peer review purposes, are that paediatric solid tumour oncologists may cover for paediatric haemato-oncologists and vice versa; and ward nurses may cover for day care nurses and vice versa.*

Compliance: Written arrangements agreed by the lead clinician of the MDT.

Core members attendance

09-7B-305 Core members or their arranged cover (see measure [09-7B-304](#)) should attend at least two thirds of the number of meetings.

Note:

Where teams deal with CNS malignancy only as part of a wider practice the neurosurgeon, neuropathologist and neurologist are not subject to this measure.

Compliance: Attendance record of the MDT.

Note:

The intention is that core members of the team should be personally committed to it, reflected in their personal attendance at a substantial proportion of meetings, not relying instead on their cover arrangements. Reviewers should use their judgement on this matter and should highlight in their report where this commitment is lacking

OPERATIONAL POLICIES (Measures [09-7B-306](#) to [09-7B-312](#))

Operational policy meeting

09-7B-306 Besides the regular meetings to discuss individual patients the team should meet at least annually to discuss, review, agree and record at least some operational policies.

Compliance: Minutes of at least one meeting agreed by the lead clinician of the MDT to illustrate the recording of at least some operational policies.

Policy for patients to be discussed by the MDT Policy for patients to be discussed by the MDT

09-7B-307 There should be an operational policy for the team which specifies:

- that all new cancer patients will be reviewed by the multidisciplinary team for discussion of initial treatment plan;
- which other situations in the patient pathway require a review by the multidisciplinary team.

Note:

As stated in the Cancer Reform Strategy, the care of all patients should be formally reviewed by an MDT.

MEASURE DETAILS & DEMONSTRATION OF COMPLIANCE

Compliance: The operational policy agreed by the lead clinician of the MDT.

Informing GP of the diagnosis

09-7B-308 The MDT should have a policy whereby after a patient is given a diagnosis of cancer the patient's general practitioner (GP) is informed of the diagnosis by the end of the following working day.

The MDT should have completed an audit against the policy of the timeliness of notification to GPs of the diagnosis of cancer.

Compliance: The written policy agreed by the lead clinician of the MDT.
The written results of the audit.

Key worker policy

09-7B-309 There should be an operational policy whereby a single named key worker for the patient's care at a given time is identified by the MDT for each individual patient and the name and contact number of the current key worker is recorded in the patient's case notes. The responsibility for ensuring that the key worker is identified should be that of the nurse MDT member(s).

The above policy should have been implemented for patients who came under the MDT's care after publication of these measures and who are under their care at the time of the peer review visit or completed self assessment.

Notes:

- *For information: according to the NICE supportive palliative care guidance, a key worker is a person who, with the patient's consent and agreement, takes a key role in co-ordinating the patient's care and promoting continuity, for example ensuring the patient knows who to access for information and advice.*
- *It may be appropriate for a paediatric oncology outreach nurse to be the key worker.*
- *It may be necessary to agree a different key worker for different parts of the patient's pathway. It is intended that at any one time a patient only has one named key worker.*
- *The key worker may be from the PTC or POSCU or community teams.*
- *This is not intended to have the same connotation as the key worker in social work. It may be necessary to agree a single key worker across both a cancer site specific MDT and the specialist palliative care MDT for certain patients.*

Compliance: The written policy agreed by the lead clinician of the MDT.
Reviewers should spot check some relevant patients' case notes.

CCLG membership of oncology core members

09-7B-310 The paediatric oncologists (solid tumour and haemato-oncology) and clinical oncologists, who are core members of the MDT, should be CCLG members.

Compliance: The membership certification of the named oncologists.

EQA membership of histopathology core members

09-7B-311 The core histopathologist member(s) of the MDT should be taking part in an EQA scheme, either a specialist scheme for the cancer site(s) of the team or a general EQA scheme which has a section covering the cancer site(s) of the team.

Compliance: Documentary evidence to show that they are taking part in a relevant EQA.

Attendance at the national communications skills training

09-7B-312 At least those core members of the team who have direct clinical contact with patients should have attended the national advanced communications skills training.

Notes:

- *This measure applies only to those disciplines which have direct clinical contact and which are named in the list in the MDT structure measure for core membership.*

MEASURE DETAILS & DEMONSTRATION OF COMPLIANCE

- Also, it applies only with regard to members which are in place i.e. If a team lacks a given core member from that list, it should still be counted as compliant with this measure provided those members which are in place comply.
- The relevant disciplines include medical, surgical, nursing and allied health professionals.
- The reviewers should record which core members of those relevant are non-compliant.

Compliance: Written confirmation of the MDT members who have attended the national advanced communications skills training programme.

MDT NURSE SPECIALIST MEASURES (Measures [09-7B-313](#) to [09-7B-315](#))

Introduction

Why are there currently 'nursing measures' for MDTs, but no similar requirements for other MDT members? The modern change to MDT working has created and then highly developed the specific role of nurse MDT member when its related activities, which in full measure, go to make up the role of cancer nurse specialist. The roles of the medical specialties in the MDT have not been so profoundly influenced or so extensively developed by their MDT membership itself compared to that of the MDT nurse members. The role definitions and training requirements of nurse MDT members are not 'officially' established outside the MDT world in contrast to the well defined medical specialties with their formal national training requirements. Therefore a particularly strong need was perceived for using the measures to define more clearly the role of the nurse member and to set out minimum training requirements for nursing input into MDTs. This is in order to establish these roles more firmly in the NHS infrastructure and to avoid the situation where MDTs can comply with measures by having generalist nurses, who 'sit in' on MDT meetings and sign attendance forms but play no defining role in the team's actual dealing with its patients.

Specialist training for core nurse member

- 09-7B-313** The MDT should have at least one core nurse member who should have successfully completed a programme of study in paediatric oncology for nurses, which has been accredited for at least 20 credits at first degree level (external training).

Compliance: Confirmation of successful completion of the course.

List of responsibilities for core nurse members

- 09-7B-314** The MDT should have agreed a list of responsibilities with each of the core nurse members of the team, which includes the following:
- contributing to the multidisciplinary discussion and patient assessment/care planning decision of the team at their regular meetings;
 - providing expert nursing advice and support to other health professionals in the nurse's specialist area of practice;
 - involvement in clinical audit;
 - leading on patient and carers' communication issues and co-ordination of the patient pathway for patients referred to the team - acting as the key worker or responsible for nominating the key worker for the patient's dealings with the team.

Note:

Additional responsibilities to those in this measure and the next measure may be agreed.

Compliance: The list of responsibilities, agreed by the lead clinician of the MDT and the core nurse member(s).

List of additional responsibilities for core nurse member

- 09-7B-315** The MDT should have agreed a list of responsibilities with at least one of the core nurse members of the team, which in addition to the items listed in measure [09-7B-314](#), includes:
- contributing to the management of the service (see note below);
 - utilising research in the nurse's specialist area of practice.

Notes:

MEASURE DETAILS & DEMONSTRATION OF COMPLIANCE

- 'Management' in this context does not mean clerical tasks involving the documentation on individual patients i.e. this responsibility does not overlap with the responsibility of the MDT co-ordinator.
- A list of responsibilities containing all the elements in this measure and the previous measure would encompass all of the domains of specialist practice required for the role of cancer nurse specialist.
- Additional responsibilities to those in this and the previous measure may be agreed.

Compliance: The list of responsibilities agreed by the lead clinician of the MDT and the relevant core nurse member(s).

FUNCTIONS OF THE TEAM (Measures [09-7B-316](#) to [09-7B-327](#))

PROVIDING PATIENT CENTRED CARE (Measures [09-7B-316](#) to [09-7B-319](#))

Patients' permanent consultation record

09-7B-316 The MDT should be offering patients the opportunity of a permanent record or summary of at least a consultation with the patient and the doctor when the following are discussed:

- diagnosis;
- treatment options and plan;
- relevant follow up (discharge) arrangements.

Note:

The MDT may, in addition, offer a permanent record of consultations undertaken at other stages of the patient journey.

Compliance: The reviewers should enquire of the working practice of the team and see anonymised examples of records given to patients.

Note:

It is recommended that they are available in languages and formats understandable by patients, including local ethnic minorities and people with disabilities. This may necessitate the provision of visual and audio material.

Patients' experience exercise

09-7B-317 The MDT should have undertaken or be undertaking an exercise during the previous two years prior to the review to obtain feedback on patients experience of the services offered.

The exercise should at least ascertain whether patients were offered:

- a key worker;
- the MDT's information for patients and carers (written or otherwise) - see measure [09-7B-319](#);
- the opportunity of a permanent record or summary of a consultation at which their treatment options were discussed.

Notes:

- *The exercise may consist of a survey, questionnaire, focus group or other method.*
- *There may be additional items in the exercise. It is recommended that other aspects of patient experience are covered.*
- *The method used for the experience should take into account any current national guidance on the age at which children's opinions may be independently sought by such experiences*

Compliance: The results (complete or in progress) of the exercise.

MEASURE DETAILS & DEMONSTRATION OF COMPLIANCE

Outcome of patients' experience exercise

09-7B-318 Exercises in [09-7B-317](#) having been completed during the previous two years should have been presented and discussed at an MDT meeting and the team should have implemented at least one action point arising from the exercise.

Compliance: The results of the exercise.
A report of the action taken.

Provision of patient written information

09-7B-319 The MDT should provide patients and carers with written material which includes:

- information specific to the MDT about local provision of the services offering the treatment for children with cancer;
- information about patient involvement groups and patient self-help groups;
- information about the services offering psychological, social and spiritual/cultural support, if available;
- information specific to children's cancer about the diseases and their treatment options (including names and functions/roles of the team members treating them).

Compliance: The written (visual and audio if used - see note below) material.
Note:
It is recommended that it is available in languages and formats understandable by patients including local ethnic minorities and people with disabilities. This may necessitate the provision of visual and audio material.

Treatment planning decision

09-7B-320 The core MDT at their regular meetings should agree and record individual patient's treatment plans. A record should be made of the treatment plan. The record should include:

- the identity of patients discussed;
- the multidisciplinary treatment planning decision;
- clinical trial considerations:
 - whether a relevant trial is available
 - if it is, whether the patient/carers will be offered entry
 - if they will not, the reasons for that decision;
- how the treatment delivery is to be divided, if at all, between the PTC and the POSCU.

Note:
A therapeutic operation may in effect form part of the initial investigation and staging procedure to render the patient suitable for discussion and for a subsequent treatment planning decision. This operation should be recorded.

Compliance: Anonymised examples of the record of a meeting and individual anonymised treatment plans.
Notes:
Only exactly what is required in the list above is necessary for evidence. Detailed minutes of the content of discussions over patients are not required for evidence. For the purposes of evidence for peer review, patient specific information should be anonymised.
It is recommended that this essential information is recorded on an MDT decision proforma as well as in individual patient's notes.

MEASURE DETAILS & DEMONSTRATION OF COMPLIANCE

CCN GUIDELINES AND PROTOCOLS (Measures [09-7B-321](#) to [09-7B-325](#))

Introduction

Where there are sub-specialist PTC MDTs, each one should agree which particular aspects of the guidelines and protocols relate to that particular team type.

PTC initial referral protocol

09-7B-321 The PTC MDT should agree their role as specified in the initial referral protocol of the CCN.

Compliance: The protocol agreed by the lead clinician of the PTC MDT.

Note:

The CCNCG, for compliance with their relevant measure should produce the protocol and the PTC, for compliance with this measure, should agree to abide by it.

PTC diagnosis and staging protocol

09-7B-322 The PTC MDT should agree their role as specified in the diagnosis and staging protocol of the CCN.

Compliance: The protocol agreed by the lead clinician of the PTC MDT

Note:

The CCNCG, for compliance with their relevant measure, should produce the protocol and the PTC, for compliance with this measure, should agree to abide by it.

PTC clinical management protocols

09-7B-323 The clinical management protocols agreed by the lead clinician of the PTC MDT

Notes:

The CCNCG, for compliance with their relevant measure should produce the protocols and the PTC, for compliance with this measure, should agree to abide by them.

The reviewers should report which specific disease protocols the MDT fails to comply with (if any).

Compliance: The clinical management protocols agreed by the lead clinician of the PTC MDT

Notes:

The CCNCG, for compliance with their relevant measure should produce the protocols and the PTC, for compliance with this measure, should agree to abide by them.

The reviewers should report which specific disease protocols the MDT fails to comply with (if any).

PTC follow up and long term sequelae protocol

09-7B-324 The PTC MDT should agree their role as specified in the follow up and long term sequelae protocol of the CCN.

Compliance: The protocol agreed by the lead clinician of the PTC MDT.

Note:

The CCNCG, for compliance with their relevant measure, should produce the protocol and the PTC, for compliance with this measure, should agree to abide by it.

PTC psychosocial assessment guidelines

09-7B-325 The MDT should agree the CCN psychosocial assessment guidelines.

Compliance: The guidelines agreed by the lead clinician of the MDT.

Note:

The CCNCG for compliance with their relevant measure should produce the guidelines and the MDT for compliance with this measure should agree to abide by them.

Minimum dataset

09-7B-326 The MDT should be collecting the data for the children's cancer minimum dataset.

Compliance: The reviewers should enquire as to the working practice of the MDT.

MEASURE DETAILS & DEMONSTRATION OF COMPLIANCE

Clinical trials entry

09-7B-327

The MDT should have recorded the numbers of patients from the CCN entered into each of the trials and studies on the CCN's list, during the previous year.

Compliance: The named trials and studies, with the numbers entered, agreed by the lead clinician of the MDT.

TOPIC 09-7C-1 - PAEDIATRIC ONCOLOGY SHARED CARE UNIT (POSCU) LEVEL 1 CORE MEASURES

Introduction

POSCU Full Level 1 Services

- Inpatient supportive care including care of children with febrile neutropoenia.
- Outpatient supportive care.
- Outpatient follow up.
- Outpatient oral chemotherapy.
- Outpatient IV bolus chemotherapy.
- Exclusions: day care infusional chemotherapy, inpatient chemotherapy and all exclusions listed in level 3.

Allowable options from the above:

- 1) all the above services.
- 2) opt out of outpatient IV bolus chemotherapy only.
- 3) opt out of outpatient IV bolus chemotherapy and Inpatient supportive care including care of children with febrile neutropoenia.
- 4) opt out of all chemotherapy and Inpatient supportive care including care of children with febrile neutropoenia.

NB: The implication of this is that any service that *is* providing outpatient IV bolus chemotherapy should also provide care for children with febrile neutropoenia.

The CCNCG should confirm which of the four options apply to the POSCU under review (see measure [09-7A-112](#)).

The option will determine which measure the POSCU will be reviewed against:

Option 1: all the [09-7C-1](#) measures.

Option 2: all the [09-7C-1](#) measures except measures [09-7C-101](#), [09-7C-102](#), [09-7C-107](#), [09-7C-108](#), [09-7C-144](#), [09-7C-147](#) and [09-7C-148](#).

Option 3: all the [09-7C-1](#) measures except measures [09-7C-101](#), [09-7C-102](#), [09-7C-104](#), [09-7C-107](#), [09-7C-108](#), [09-7C-111](#), [09-7C-116](#), [09-7C-144](#), [09-7C-147](#) and [09-7C-148](#).

Option 4: all the [09-7C-1](#) measures except measures [09-7C-101](#), [09-7C-102](#), [09-7C-103](#), [09-7C-104](#), [09-7C-106](#), [09-7C-107](#), [09-7C-108](#), [09-7C-111](#), [09-7C-112](#), [09-7C-116](#), [09-7C-123](#) to [09-7C-151](#).

MEASURE DETAILS & DEMONSTRATION OF COMPLIANCE

The responsibility for review purposes for the measures [09-7C-101](#) to [09-7C-151](#) lies with the lead clinician of the POSCU.

Note:

The lead clinician of the POSCU would normally be expected to act as the head of service of the POSCU chemotherapy service.

POSCU FACILITIES MEASURES (Measures [09-7C-101](#) to [09-7C-110](#))

POSCU level 1 policy for the location of outpatient chemotherapy delivery

09-7C-101

Outpatient IV bolus chemotherapy should only be given in specified room(s) covered by a policy whereby:

- on the sessions the IV chemotherapy is being given the room(s) should only be used for this purpose or other outpatient or day care clean treatment or procedures.

Note:

Such terms as 'departments', 'units', 'suites', 'areas' and 'facilities' etc, are all difficult to define with precision but they are all made up of a room or rooms.

Compliance: The policy, specifying the room(s), agreed between the head of service and the relevant hospital manager.

The reviewers should enquire of the hospital's working practice.

MEASURE DETAILS & DEMONSTRATION OF COMPLIANCE

Availability of specific regimens/protocols/emergency equipment

09-7C-102 The areas/wards/rooms identified in measures [09-7C-104](#) to [09-7C-108](#) should have available to them:

- the regimen details for the regimens in use
- protocol documents and equipment for the management of at least the following emergencies:
 - anaphylactic shock
 - extravasation of cytotoxics
 - cardiac arrest
 - spillage of cytotoxics.

Compliance: The reviewers should inspect the information in those locations.

Area for temporary storage of chemotherapy agents

09-7C-103 The areas/wards/rooms identified in measures [09-7C-104](#) to [09-7C-108](#) should have within them, or adjacent to them, a separate and identified area for the temporary storage of chemotherapy agents which have been dispensed from pharmacy and for tasks involved in preparation and delivery of treatment.

The storage area should have a lockable fridge and cupboard specifically for the storage of chemotherapy agents.

Note:

These tasks refer to those which the service decides do not need to be done in a specialised, clean pharmacy preparation unit.

Compliance: The reviewers should view the rooms.

Availability of single rooms for inpatient isolation

09-7C-104 The POSCU should have an agreed number of single rooms (not one room only), to be used for inpatient isolation, each with en-suite toilet and washing facilities.

Compliance: The number agreed by the head of service and the relevant hospital manager.
The reviewers should view the rooms.

Area for paediatric oncology clinic

09-7C-105 The outpatient clinic specified in the 'paediatric oncology clinic' measure [09-7C-109](#) should be held such that it, together with its waiting area, is spatially or temporally separated from all other outpatient's clinics.

Compliance: The hospital outpatient department weekly schedule.
If relevant, the reviewers should view the department.

Note:

This measure is designed to reduce the exposure of patients to the risk of cross-infection

DAY CARE/OUTPATIENT TREATMENT FACILITIES (Measures [09-7C-106](#) to [09-7C-109](#))

The day care facilities (this is likely to be a common day care/outpatient facility) should have

Day care waiting room

09-7C-106 A waiting room exclusive to the use of the patients and carers using the day care facility on the days it is being used as such.

Compliance: The reviewers should enquire as to the hospitals working practice.

Note:

Practices more rigorous than this - i.e. waiting areas permanently exclusive to such patients, obviously also comply.

Availability of day care paediatric resuscitation equipment

09-7C-107 Paediatric resuscitation equipment in the room(s) where day care treatment takes place. There should be an equipment check at least weekly.

MEASURE DETAILS & DEMONSTRATION OF COMPLIANCE

Compliance: The reviewers should view the equipment and enquire as to the hospital's working practice.

Note:
This measure is not intended to produce a detailed inspection of the contents and type of equipment.

Day care recovery rooms

09-7C-108

Day care recovery beds - i.e. a ward or part of a ward, or room(s) with day beds, covered by a policy whereby:

- on the sessions that the POSCU's day care facility is being used the rooms are used only for its patients who are resting after day care treatments or after invasive investigation, or for other outpatients who have had clean day care procedures.

Note:

The above facility is required but it is acceptable practice for children to recover initially in a general recovery area before transferring to a children's recovery area.

Compliance: The policy, specifying the rooms, agreed by the head of service and the relevant hospital manager.
The reviewers should view the facilities.

Paediatric oncology clinic

09-7C-109

There should be a regular (scheduled) outpatient clinic at a host hospital of the POSCU which:

- i) should be identified in the hospital's outpatient department clinic list or timetable as a clinic for patients under the care of the POSCU;
- ii) should have a facility for physically separating oncology patients from potentially infectious patients;
- iii) should be identified, together with a contact point for referral, in the initial referral protocol specified in measure [09-7A-113](#);
- iv) should have the lead clinician of the POSCU as a member of its medical staffing.

Compliance: Hospital outpatient department timetable or clinic list.
For point (ii), the reviewers should enquire as to the hospital's working practice.
The relevant extract from the initial referral protocol.
Work plan of the lead clinician of the POSCU.

The oncology ward

Note:

The term oncology ward is used for peer review purposes only to denote the ward which is defined in the measure below. The local name for such a ward or any other specialties which may occupy this ward is not subject to review.

The oncology ward

09-7C-110

There should be a written policy whereby paediatric oncology patients should be cared for on a single named children's ward where this is agreed as part of the ward's regular activity and to which patients are admitted in preference to other wards.

Notes:

- *Where there is only one ward for children in the host hospital of the POSCU this is automatically compliant.*
- *Where there is a ward reserved exclusively for paediatric oncology patients this is automatically compliant.*

Compliance: The policy, naming the ward, agreed between the lead clinician of the POSCU and the relevant hospital manager. The reviewers should enquire of the hospital's practice.

MEASURE DETAILS & DEMONSTRATION OF COMPLIANCE

NURSE NUMBERS AND TRAINING LEVELS (Measures [09-7C-111](#) to [09-7C-112](#))

Introductory Note

It is an underlying assumption of these measures that where a 'nurse' is referred to without any further specification this refers to a registered sick children's nurse, or registered nurse (child). Any other qualifications referred to are in addition to these initial qualifications.

POSCU level 1 foundation internal training for oncology ward nurses

09-7C-111 This measure is applicable only to those level 1 POSCUs which are agreed by the CCNCG as offering inpatient care to children with febrile neutropenia.
A minimum of two, day and night, nurses working on the **oncology ward** should be trained at least to the 'foundation internal' training level as specified in the introduction.

Compliance: The number (head count) on the oncology ward; a current duty roster for the ward.
The training certification of the relevant nurses.

POSCU level 1 training for day care nurses

09-7C-112 At least one nurse on duty during each shift that the **day care facility** is open for chemotherapy should be trained at least to the 'full internal' training level as specified in the introduction.
On days that the facility is open but **not** for chemotherapy, there should be at least one nurse during each shift, trained at least to the 'foundation internal' level specified in the introduction.

Compliance: The named nurses and their training certification.
A current duty roster for the day care facility.

MEDICAL STAFFING (Measures [09-7C-113](#) to [09-7C-117](#))

Note:

The role of lead clinician of the POSCU should be undertaken by the lead clinician of the POSCU MDT as is dealt with in measure [09-7C-401](#).

Deputy lead clinician and responsibilities

09-7C-113 There should be a named deputy lead clinician for the POSCU.
They should agree the responsibilities of the role with the lead clinician of the POSCU.

Note:

The deputy need not be a consultant, but if not they should be a non-consultant career-grade post.

Compliance: The named deputy and the responsibilities of the role, agreed by the lead clinician of the POSCU.

Workload assessment of lead clinicians

09-7C-114 A workload assessment should be carried out for the lead clinician and deputy lead clinician, based on a workload diary for each clinician over a specified six month period.

Compliance: The workload assessment.

Specified PAs for lead clinician and deputy lead clinician

09-7C-115 The lead clinician and deputy lead clinician should agree with their clinical director (or equivalent) in the host trust, an estimate of the number of DCC PAs and supporting PAs for each clinician which are needed for the work of the POSCUs.

The estimated number of PAs should be included in the job plans of the lead clinician and deputy lead clinician.

Note:

If the lead clinician or deputy lead is the clinical director the estimate should be agreed with the medical director of the host trust.

MEASURE DETAILS & DEMONSTRATION OF COMPLIANCE

Compliance: The number of PAs agreed by the clinical director.
The job plans.

Resident medical cover rota

09-7C-116 Applicable to level 2 and 3 POSCUs and only those level 1 POSCUs which have been agreed as accepting patients with neutropenic sepsis.

There should be a resident cover rota for the POSCU whereby there is 24/7 cover, resident on-call from medical staff of ST3 minimum level of seniority.

Notes:

- *Non-consultant specialist career grades may also take part.*
- *The ST3s and career grades may specialise in paediatric oncology or general paediatrics or other branches of acute paediatrics.*

Compliance: An example of a rota showing named doctors agreed by the lead clinician of the POSCU.

POSCU role in CCN medical cover

09-7C-117 The POSCU should agree its role in the CCN medical cover arrangements (measure [09-7A-125](#)).

Compliance: The cover arrangements agreed by the lead clinician of the POSCU.

Note:

The CCNCG for compliance with their relevant measure should produce the arrangements and the POSCU, for compliance with this measure, should agree to abide by them.

CCLG membership of lead clinician

09-7C-118 The POSCU lead clinician should be a member or associate member of the children's cancer and leukaemia group (CCLG).

Compliance: Written proof of membership.

Protocol co-ordinator

09-7C-119 There should be a named person at the POSCU who should be a core member of a POSCU MDT, who has the responsibility for receiving, acknowledging, archiving and distributing CCN protocols and protocol amendments.

They should agree a list of responsibilities of the role with the lead clinician of the POSCU.

Note:

The person need not be clinical. The role need not necessarily be full time, but should have specified time their job description.

Compliance: The named person agreed by the lead clinician of the POSCU.
The list of responsibilities agreed by the lead clinician of the POSCU.
The specified time.

Proposals for service development plan

09-7C-120 The POSCU's proposals for the service delivery plan for the three years subsequent to the publication of these measures should be incorporated into the 'proposals for the service development' of the relevant locality group in their host cancer network.

Their proposals should be sent to the CCNCG for prioritisation and used towards the CCN's service delivery plan.

Compliance: The locality group's proposals for local development and a written communication by the locality group to the CCNCG; all agreed by the chair of the locality group and the lead clinician.

MEASURE DETAILS & DEMONSTRATION OF COMPLIANCE

Cancer services directory of the POSCU locality

09-7C-121

The following should be included in the cancer services directory of the POSCU's locality:

- i) the core members of the POSCU MDT and the contact point for the team;
- ii) the location of the POSCU chemotherapy service and contact points for the 24-hours chemotherapy advice service;
- iii) the contact point for the paediatric oncology palliative care service and 24-hour palliative care advice;
- iv) the location of and contact points for the paediatric radiotherapy service;
- v) the location and core members of the PTC diagnosis and treatment MDT and the contact point for the team;
- vi) the location and core members of the TYA MDT and the contact point for the team;
- vii) the patients' and carers' support groups which the CCNCG endorses with local contact points;
- viii) the psychological support and bereavement support services.

Notes:

- *This directory may include additional information on paediatric oncology services.*
- *A network directory may be developed - including PTC and POSCU services in a single combined directory.*
- *Any trust providing chemotherapy to children must also be assessed against existing chemo measures.*

Compliance: The directory agreed by the chair of the locality group.

24-hour telephone advice service

09-7C-122

The POSCU should agree the minimum service specification with the PTC and should specify in particular (see measure [09-7B-128](#)):

- the contact number(s) they will use;
- the specified staff they will provide and for which parts of a 24-hour rota;
- their locally applicable policy for instructions to patients and carers.

Notes:

The POSCU may agree to provide a 24-hour rota exclusively for their own service, or may contribute staff to a service shared with other parts of the CCN. This is for agreement with the PTC.

The POSCU may agree to the service being provided entirely by the PTC.

Compliance: The written specification agreed by the chair of the CCNCG and the lead clinician of the POSCU with the local features as specified above.

The reviewers should enquire whether the POSCU is providing its agreed contribution to the rota.

Note:

The CCNCG, for its compliance with its relevant measure, should produce the specification and the POSCU, for its compliance with this measure, should agree with it and provide its contribution.

THE POSCU CHEMOTHERAPY MEASURES (Measures [09-7C-123](#) to [09-7C-140](#))

Introduction

Other than surgical treatment and radiotherapy the definitive treatment of children with malignancy for the purpose of peer review, is considered to be carried out by the specialty of paediatric oncology. Within this group, there is usually subspecialisation into paediatric solid tumour treatment specialists and specialists in the treatment of paediatric haematological malignancy. The term paediatric haematology is, for the purpose of peer review, taken to mean the specialty which treats children with non-malignant haematological disorders and is outside the scope of the measures and peer review.

The treatment of children with radiotherapy is carried out by the clinical oncology specialty, usually by specialists who also have an adult radiotherapy practice.

The chemotherapy service of the POSCU is reviewed under measures [09-7C-123](#) to [09-7C-140](#). All the

MEASURE DETAILS & DEMONSTRATION OF COMPLIANCE

chemotherapy facilities and staff and chemotherapy related activities which come under the measures are reviewed as one entity for the POSCU. This entity is what is referred to as 'the chemotherapy service'. For example, there should be a single head of service for all chemotherapy for the POSCU.

The chemotherapy measures refer to 'the chemotherapy service'. Prior to these measure and the peer review of children's cancer services, it may not have been conventional for the staff involved to consider themselves as part of such a defined entity as could be identified by a label like 'the chemotherapy service' - prescribing and administering chemotherapy were just part of the job as a whole.

However, if definite quality measures are going to be applied in reality to the structures and processes involved in children's chemotherapy, then the compliance with these measures has to be verified 'on the ground' in relation to concrete existing practices. Thus a peer review visit has to relate to a recognised, declared set of people and facilities, with some boundary between them and whoever is going to be reviewed by a different visit. Also this allows for consistency of practice - for example, a set of practice guidelines are understood to apply across the whole of the defined service, which prevents groups of staff disagreeing over practice and asking to be peer reviewed separately. In the case of children's chemotherapy the service is also defined by the age boundary, with the provisions regarding flexibility as stated in the introduction to the children's cancer measures. In common with the rest of the Manual for Cancer Services, the responsibility for peer review purposes of every measure is attributed to some named person or other. For chemotherapy this person is termed the 'head of service', which again may be a somewhat new role for some organisations. The same considerations apply to an oncology pharmacy service and the lead pharmacist.

Future revisions of the children's cancer chemotherapy measures may need to take into account any general changes in national guidance on chemotherapy which follow such reviews as the NCEPOD enquiry into chemotherapy and the reports of the NCAG.

Nomenclature.

The term '**chemotherapy**' refers to the use of those cytotoxic agents commonly understood and accepted as being covered by this term. The inclusion of certain other agents which may or may not be understood to fall clearly into this group is permissible - for example biological therapies. The exact extent of the drugs to be included under the remit of the measures is a matter for local discretion unless otherwise stated in the measures themselves. It will largely be manifested by which regimens and which supportive drugs are named in the CCN list and local lists of regimens.

For this set of measures, **systemic, intravenous, intramuscular, oral and subcutaneous** chemotherapy is included. Topical and intracavity chemotherapy is not included. The position regarding **intrathecal** chemotherapy is dealt with separately.

In the measures, chemotherapy is referred to as being given over a complete period of treatment known as a **course**, which consists of giving the drugs over a repeated pattern known as a **cycle**. For entirely oral chemotherapy a cycle may be defined by the length of time in between mandatory reviews. The maximum intended number of cycles and therefore the intended length of the course may be pre-determined or **fixed**, or dependent on various factors and therefore **indeterminate or variable** from the outset. The separate occasions when drugs are given within a cycle are termed **administrations**. These are usually understood to refer to occasions of parenteral administration rather than say daily oral doses, oral treatment being referred to in the conventional way of pharmacological prescriptions.

None of the above terms as used in these measures are intended to have any other meanings or connotations other than those stated. Where a measure is intended to refer to a particular level of professional training or seniority it will be stated. If it is local practice to use different terms, meanings or connotations, this is not a matter for the measures or peer review.

The responsibility for review purposes for measures [09-7C-123](#) to [09-7C-140](#) lies with the head of service.

The head of service list of responsibilities

09-7C-123

The head of service should agree a list of responsibilities for the role with the lead cancer clinician of the trust involved in the chemotherapy service and the head of service's line manager.

Note:

The head of service would normally be expected to be the lead clinician of the POSCU - see [09-7A-105](#).

Compliance: The list of responsibilities agreed by the lead cancer clinician and the line manager.

POSCU list of acceptable regimens

09-7C-124

The head of service should agree the list of acceptable regimens for the service with the CCNCG and the network chemotherapy group of the host cancer network of the POSCU. The list should be compatible with the agreed care level of the POSCU and should be updated annually.

MEASURE DETAILS & DEMONSTRATION OF COMPLIANCE

The service should agree the list (specified in measure [09-7A-130](#)) of regimens, parts of regimens, routes and settings which identify the permissible practice of nurses who have undergone only the CCN's low risk training programme in chemotherapy administration.

Notes:

- For compliance with measure [09-7A-130](#) the CCNCG should agree the list of regimens for the CCN across the PTC and all POSCUs and levels; and the POSCU, for compliance with this measure should agree its service's list compatible with the list for the CCN.
- For level 2 and 3 POSCUs, the list should specify which regimens should be allowed as day care regimens which can be given at the POSCU.
- For level 3 POSCUs, the list should specify which regimens should be allowed as inpatient regimens which can be given at the POSCU.

Compliance: The POSCU list (or updated, see below) for the year prior to the review visit or completed self assessment, as hard copy or on a computerised prescribing system, agreed by the chair of the CCNCG and the head of service.

For POSCUs established for two or more years since the publication of these measures the lists are needed from the first year, then the agreed updates for each subsequent complete year up to the peer review visit or completed self assessment.

Policy for preventing regular use of regimens not on the agreed list

09-7C-125

The head of service should agree a written policy with the CCNCG for preventing regular use of regimens not on the accepted list. The policy should state:

- the exceptional circumstances under which such a regimen could be used;
- the procedure which is then required to authorise it.

Note:

The CCNCG should produce the policy for its compliance with measure [09-7A-131](#) and the POSCU should agree to abide by it for its compliance with this measure.

Compliance: The written policy agreed by the chair of the CCNCG and the head of service.

Record of the use of unlisted regimens

09-7C-126

The chemotherapy service should record, for review by the CCNCG, the instances of the use of a regimen which is not on the agreed list. They should record in each case:

- the regimen used;
- the indication for its use.

Compliance: The record of the use of regimens which are not on the agreed list.

GUIDELINES/PROTOCOLS FOR HOSPITAL STAFF FOR THE PREVENTION AND TREATMENT OF THE COMPLICATIONS OF CHEMOTHERAPY (Measures [09-7C-127](#) to [09-7C-140](#))

Introduction

The term guidelines/protocols is used since some parts may be in the form of general advice (guidelines) and some may be in the form of precise instructions (protocols). They may form part of a wider ranging set of information. There may be different documents for solid tumour oncology than for haemato-oncology or there may be documents common to both. All these options are acceptable providing measures [09-7C-127](#) to [09-7C-140](#) are complied with. They should all be agreed by the head of service.

Guidelines/protocols on pre-chemotherapy investigations

09-7C-127

There should be guidelines/protocols covering laboratory blood tests and other investigational parameters to be fulfilled prior to starting chemotherapy, before a whole course and before individual cycles, covering both generic parameters and those specific to the regimens on the services agreed list.

Note:

It would be easy to make this measure impossible to comply with because of the open-ended range of possible parameters. Reviewers are required to exercise their discretion to judge whether this issue has been realistically addressed.

MEASURE DETAILS & DEMONSTRATION OF COMPLIANCE

Compliance: The written guidelines/protocols, agree by the PTC and POSCU heads of service.

General chemotherapy guidelines/protocols

09-7C-128

There should be guidelines/protocols covering the following:

- cytotoxic administration techniques
- the care of those venous access devices used by the service, including the treatment of line complications
- the recognition and treatment of neutropenic sepsis
- the use of blood products
- the prevention and treatment of cytotoxic-induced emesis
- the recognition and treatment of cytotoxic extravasation
- the recognition and treatment of allergic reactions including anaphylaxis
- the prevention and treatment of stomatitis, other mucositis and diarrhoea.

Note:

Reviewers should check guidelines and protocols are appropriate for children's cancer.

Compliance: The written guidelines/protocols as agreed by PTC and POSCU heads of service.

Regimen-specific guidelines/protocols

09-7C-129

There should be guidelines/protocols for the treatment and/or prevention of regimen-specific complications not included in the above measure and relevant to the regimens on the services agreed list of regimens.

Note:

The following are by way of illustration and may not all be applicable:

- *IV pre and post-hydration*
- *folic acid rescue*
- *the use of MESNA*
- *the prevention of serious hypersensitivity reactions.*

Compliance: The written guidelines/protocols as agreed by PTC and POSCU heads of service.

Note:

It would be easy to make this measure impossible to comply with because of the open-ended range of possible complications and remedies. The reviewers are required to exercise their discretion to judge whether this issue has been realistically addressed.

RECORDING OF CHEMOTHERAPY TREATMENT (Measures [09-7C-130](#) to [09-7C-132](#))

These measures address, for specified parts of the pathway, the content of the records, not who does the recording or where the records are kept, or any other aspects of the use of records. The same record contents should be available at PTC and POSCU for a given patient who receives parts of their treatment at the PTC and at a POSCU.

Pre-course records

09-7C-130

There should be treatment records for each patient fulfilling the following minimum criteria prior to the start of a **course** of chemotherapy:

- patient identification
- weight, height, surface area
- cancer type
- regimen and doses (including all cytotoxic chemotherapy drugs to be used and elective essential support drugs other than antiemetics); trial name or number, if applicable
- route of administration (oral, IV, IV infusion, IM, SC)
- number of cycles intended
- frequency of cycles and of administrations within a cycle
- investigations necessary prior to starting the whole course
- investigations to be performed serially during the course (to detect/monitor both toxicity and response) and their intended frequency

MEASURE DETAILS & DEMONSTRATION OF COMPLIANCE

- number of cycles
- attendances managed by agreed non-medical staff, for example nurse led attendances
- site of administration (PTC, POSCU, community).

Compliance: Reviewers should examine examples of patients' chemotherapy records or the computerised prescribing programme.

Pre-cycle records

09-7C-131 There should be treatment records for each patient fulfilling the following minimum criteria, prior to each **cycle**:

- the results of essential serial investigations applicable to that cycle (and prior to an administration within a cycle, if applicable);
- any dose modifications and whether or not they are intended to be permanent;
- any cycle (or administration) delays;
- any introduced support drugs not recorded under measure [09-7C-130](#).

Compliance: Reviewers should examine examples of patients' chemotherapy records, or computerised prescribing programme.

Post-course records

09-7C-132 There should be treatment records for each patient fulfilling the following minimum criteria, **after the final cycle** is given in a course:

- whether the course was completed or not;
- if not completed - the reasons for cessation;
- for completed courses of non-adjuvant treatment a reference to the response should be included.

Compliance: Reviewers should examine examples of patients' chemotherapy records or computerised prescribing programme.

Verification procedure

09-7C-133 There should be a verification procedure, which is carried out before each physical administration of chemotherapy, to ensure that the following aspects are correct:

- patient's identification, as agreed with the patient on that occasion, on the prescription chart and on all labelled drugs
- critical test results
- regimen and individual drug identification
- diluents and dilution volumes, and any hydration
- that supportive drugs have been given as per prescription
- administration route and duration
- cycle number
- the administration as per the schedule within the cycle.

Compliance: The written procedure agreed by the head of service.
Reviewers should enquire of the local practice.

Out of hours chemotherapy policy

09-7C-134 There should be a policy for the chemotherapy service, agreed with the supporting oncology pharmacy service(s) and the relevant hospital manager(s), stating:

- in which, and only which, exceptional circumstances the initiation of an administration of chemotherapy may be allowed outside "normal working hours";
- the arrangements for administering chemotherapy which then apply.

Notes:

- *The exact definition of "normal working hours" should be agreed locally as part of the policy.*

MEASURE DETAILS & DEMONSTRATION OF COMPLIANCE

- *It is widely accepted and strongly recommended that chemotherapy should, as far as possible, take place during normal working hours. It is more practical, however, from the point of view of a precise review measure, to define and agree the few exceptions to this rule.*

Compliance: The policy agreed by the head of service, the lead pharmacist(s) of the supporting oncology service(s) and the relevant hospital manager(s).

TRAINING FOR STAFF ADMINISTERING CHEMOTHERAPY (Measures [09-7C-135](#) to [09-7C-140](#))

Introduction

The CCNCG should agree a nurses' training programme in chemotherapy administration using the RCN competencies with special modifications for training for low risk treatments and for medical staff administering chemotherapy.

There should be a named experienced and trained chemotherapy nurse for each chemotherapy service who should be responsible for training and assessing the competencies of staff. Each chemotherapy service should maintain a list of those staff who are competent and authorised to administer chemotherapy. There are exemptions at first for those who are already trained and experienced. (See the introduction to the children's cancer measures).

It takes time to implement this, so the significance of a service's failure to have only authorised staff administering chemotherapy increases with the run up time available to them before the service's peer review. Lack of compliance should be a matter for discussion between the zonal peer review co-ordinating team and the relevant SHA.

The measures in this section should be applied to each chemotherapy service.

Chemotherapy nurse trainer

09-7C-135

There should be a named chemotherapy nurse for the clinical chemotherapy service with responsibility for training in chemotherapy administration.

The nurse should be qualified to 20 credits at first degree level in paediatric oncology including one module or more in chemotherapy administration and:

the nurse should be currently administering chemotherapy for part of the time, with a minimum of two years previous experience in chemotherapy administration.

The named nurse trainer in the previous measure should:

- have an agreed list of responsibilities which should include:
 - i) choosing nurses who are initially judged able to act as assessors of competence in chemotherapy administration.
Notes:
This responsibility applies only to the first round of peer review against these measures. Once the CCN training programme is established and reviewed it is intended that assessors appointed subsequently would be qualified according to these measures.
 - ii) ensuring that staff administering chemotherapy in the service are trained and assessed for competence according to the RCN standards specified in the introduction or have met the exemption requirements as specified in the introduction;
 - iii) assessing the competence by APEL of nurses trained by other systems to be assessors or authorised administrators of chemotherapy.
- have an agreed minimum time allowed for those responsibilities in their weekly timetable.

Notes:

- *The named nurse may have had two years experience of chemotherapy administration partially or wholly in another clinical chemotherapy service of the CCN or (with the CCNCG chair's agreement) in another CCN.*
- *The service under review may name more than one nurse trainer, or may share a trainer with other POSCUs and/or the PTC or training could be provided entirely by the PTC. In the latter case, measure [09-7B-146](#) would have the same compliance evidence as the PTC.*

Compliance: The named nurse agreed by the head of service of the chemotherapy service under

MEASURE DETAILS & DEMONSTRATION OF COMPLIANCE

review.
The confirmation of completion of study.
The start date in chemotherapy administration.
The list of responsibilities and the portion of time agreed by the head of service.

List of staff authorised to give chemotherapy (nursing)

09-7C-136 The service should maintain a list of named nursing staff, who have been assessed as competent to administer chemotherapy unsupervised, having met the RCN standards specified in the introduction. The list should separately identify those having received low risk training as competent to administer the selected treatments identified in measure [09-7A-136](#).

Note:

See the measure below for inclusion of medical staff on the list.

Compliance: The list of authorised staff agreed by the head of service.
The reviewers should enquire of the working practices of the service in relation to conditions allowing inclusion on the list.

Administration authorisation policy

09-7C-137 The service should agree a policy to the effect that chemotherapy administration staff who are not authorised on the list as defined in measure [09-7C-136](#) may administer chemotherapy only as part of their training and assessment and in the presence of authorised staff.

Compliance: The policy agreed by the head of service. The reviewers should enquire as to the working practices of the department.

Provision of training

09-7C-138 The service should agree to provide the CCN's agreed training programme for its staff, including the agreed part of the programme for medical staff and the low risk training programme.

Compliance: The programme summary agreed by the chair of the CCNCG and the head of service.

List of staff authorised to give chemotherapy (medical)

09-7C-139 There should be a list for the chemotherapy service of medical staff authorised to administer chemotherapy. The service should include the following, and only the following, medical staff on the list:

- those who have been trained and reviewed according to the CCN's agreed programme for medical staff;
- those who have received training according to the previous Manual of Cancer Services Measures (2004);
- those in post administering chemotherapy for two or more years prior to the publication of these measures.

Note:

The service may wish to offer training to the latter category of staff and may wish to make this a pre-condition for their inclusion on the list.

Compliance: The list agreed by the head of service.
The reviewers should enquire of the working practice of the service in relation to conditions allowing inclusion on the list.

Prescribing policy

09-7C-140 The service should agree a prescribing policy to the effect that:

- the decision to treat with a course of chemotherapy and the choice of a particular regimen should only be taken by a consultant paediatric oncologist;
- the prescribing of the first cycle of a course of that previously chosen regimen should be done by consultant paediatric oncologist or specialist NCCG in paediatric

MEASURE DETAILS & DEMONSTRATION OF COMPLIANCE

oncology or specialist trainee at SP3 level or above.

The policy should be distributed to consultants using the service, medical staff working in their firms or treating their patients oncologically, lead pharmacist(s) and lead nurse(s) associated with the service.

Compliance: The policy agreed by the head of service.

The reviewers should enquire as to the distribution process.

Notes:

Parts of the compliance evidence may be provided by the security password system of a computerised prescribing system.

Minor short falls in the completeness of the distribution should not preclude compliance with this measure.

The service may agree a more restrictive policy to that specified, or may agree a policy covering the prescribing of cycles subsequent to the first cycle. This is not subject to review.

POSCU ONCOLOGY PHARMACY SERVICES (Measures [09-7C-141](#) to [09-7C-146](#))

Introduction

The clinical chemotherapy service in the PTC or in a POSCU may receive its pharmacy support from a pharmacy which has previously been reviewed as part of the peer review of "adult" cancer services.

If, at such a previous review, there was compliance with the measures regarding preparation facilities and COSHH, they will be regarded as compliant for the review of children's cancer services provided it is within the time frames stated in those measures.

The remaining oncology pharmacy measures should be applied specifically and separately with regards to the children's service.

The responsibility for review purposes for these measures lies with the lead pharmacist.

List of responsibilities for the lead pharmacist

09-7C-141

The lead pharmacist should agree a list of responsibilities for the role with the lead cancer clinician(s) of the trust(s) involved in the service and the lead pharmacist's line manager.

Note:

See the notes below for the case where the lead pharmacist is the only designated pharmacist for the service.

Compliance: The list of responsibilities agreed by the lead cancer clinician(s) and the line manager.

DESIGNATED PHARMACISTS (Measures [09-7C-142](#) to [09-7C-150](#))

Introduction

The duties identified in measures [09-7C-143](#) and [09-7C-144](#) may be divided between more than one designated pharmacist. These need not be their only duties. The duties in measure [09-7C-145](#) should be assigned to a single designated pharmacist. Where the oncology pharmacy service under review has only one pharmacist, they should take the role of designated pharmacist as well as lead pharmacist, and should have all the duties of measures [09-7C-143](#) to [09-7C-145](#) in their list of responsibilities.

Designated pharmacists for the service

09-7C-142

There should be one or more named pharmacists for the service whose role is defined by the duties described in measure [09-7C-143](#) below. For review purposes these pharmacists are termed "designated pharmacists".

Note:

The role of designated oncology pharmacist need not occupy the whole of a pharmacist's duties.

Compliance: The named designated pharmacist(s) agreed by the lead pharmacist.

MEASURE DETAILS & DEMONSTRATION OF COMPLIANCE

List of responsibilities for the designated pharmacist

- 09-7C-143** The following duties should be included in the list of responsibilities of a designated pharmacist agreed by the lead pharmacist and the relevant line manager for the children's chemotherapy services declared as being supported by the pharmacy service under review:
- liaison with PTC pharmacist;
 - overall responsibility for oncology services to the named wards/areas/outpatient facilities used exclusively or preferentially for chemotherapy and clean procedures;
 - overall responsibility for oncology services to the outpatient services on the days they are used for chemotherapy;
 - overall responsibility for cytotoxic chemotherapy.

Compliance: The list of responsibilities of the relevant named designated pharmacist(s) agreed by the lead pharmacist and the relevant line manager.

Responsibility for the preparation facilities

- 09-7C-144** The following duty should be included in the list of responsibilities of a single designated pharmacist:
- overall responsibility for the clean chemotherapy preparation facilities of the pharmacy service.

Note:

This could instead be on the list of responsibilities of a designated pharmacist of an adult oncology pharmacy service.

Compliance: The list of responsibilities of the relevant named designated pharmacist agreed by the lead pharmacist and the relevant line manager.

Pharmaceutical responsibility for chemotherapy related research

- 09-7C-145** The following duty should be included in the list of responsibilities of a designated pharmacist:
- liaison over pharmaceutical matters with investigators carrying out clinical trials and/or other clinical research involving the drug treatment of malignant diseases.

Note:

These are investigators working in the children's chemotherapy services supported by the pharmacy service under review.

Compliance: The list of responsibilities of the relevant named designated pharmacist(s) agreed by the lead pharmacist and the relevant line manager.

Pharmacy department organisational chart

- 09-7C-146** The managerial relationship of the lead pharmacist and, if applicable, the designated pharmacists to the rest of the pharmacy department of the hospital hosting the oncology pharmacy service, should be defined by an organisational chart.

Note:

When a specialist hospital has a pharmacy dealing entirely in oncology this measure should be discussed specifically with reviewers

Compliance: The organisational chart agreed by the lead pharmacist and the head of the hospital pharmacy department.

MEASURE DETAILS & DEMONSTRATION OF COMPLIANCE

PREPARATION FACILITIES (measures [09-7C-147](#) and [09-7C-150](#))

Introduction to preparation facilities and COSHH

The POSCU chemotherapy service may receive its pharmacy support from a pharmacy which has previously been reviewed as part of a peer review of "adult" cancer services. The evidence from this, provided for compliance with the measures regarding preparation facilities and COSHH, may serve as evidence for this current review if it is within the allowable timeframes. The remaining oncology pharmacy measures in this section should be applied separately and specifically with regards to the children's cancer chemotherapy service.

External pharmacy audit

09-7C-147 The oncology pharmacy service should have been independently audited for at least the clean preparation of compounds and the preparation of chemotherapy and should have agreed to abide by its findings.

The audit should be conducted as follows:

- licensed units - Medicines and Healthcare Products Regulatory Agency inspection within two years prior to the peer review visit or completed self assessment;
- unlicensed units - an external audit by the Regional Quality Assurance Pharmacist within eighteen months prior to the peer review visit or completed self assessment.

Compliance: The results of the inspection or external audit agreed by the lead pharmacist.

Outcome of the external pharmacy audit

09-7C-148 If the inspection/audit identified in the previous measures requires any matters to be dealt with there should be remedial actions agreed for this. Any resulting proposals for investment should have been presented to the head(s) of the pharmacy department(s) of the host hospital(s) and to the relevant locality group.

Compliance: The remedial actions agreed by the lead pharmacist.
The reviewers should enquire if there were any investment proposals and if they have been presented to the head(s) of pharmacy and the locality groups.

COSHH service review

09-7C-149 The lead pharmacist and an authorised COSHH advisor should have met to review the service against the current COSHH regulations. Any recommendations and/or results of the review should have been made known to the lead manager responsible for risk management in the host NHS trust.

Compliance: The minutes of the meeting and a written submission to the trust risk manager, both agreed by the head of service and having taken plan within the year preceding the peer review visit or completed self assessment.

Prescriptions checked and authorised by a pharmacist

09-7C-150 All cytotoxic chemotherapy prescriptions should be checked and authorised by a pharmacist.

Compliance: Reviewers should spot check prescriptions and/or examine the relevant computerised prescribing software security system.

MEASURE DETAILS & DEMONSTRATION OF COMPLIANCE

POSCU radiotherapy

The responsibility for review purposes for the radiotherapy measure lies with the head of service of the radiotherapy department.

POSCU radiotherapy

09-7C-151

The department's techniques and dose/fraction schedules for its children's radiotherapy treatments should be agreed between a consultant clinical oncologist core member of the PTC diagnostic and treatment MDT and the head of service of the radiotherapy department under review.

Note:

The POSCU-associated radiotherapy department should only be offering palliative radiotherapy treatments.

Compliance: The techniques and schedule agreed by the core MDT member and the head of service.

Note:

If there are subspecialist PTC MDTs for the CCN under review and the clinical oncologist core MDT members vary between the MDTs, the regimens should be agreed by all relevant clinical oncology core members.

TOPIC 09-7C-2 - PAEDIATRIC ONCOLOGY SHARED CARE UNIT (POSCU) LEVEL 2 CORE MEASURES

POSCU Level 2 Services

- Inpatient supportive care including care of children with febrile neutropenia.
- Outpatient supportive care.
- Outpatient follow up.
- Outpatient oral chemotherapy.
- Outpatient IV bolus chemotherapy.
- Day care infusional chemotherapy.
- Exclusions: inpatient chemotherapy and all exclusions listed in level 3.

MEASURE DETAILS & DEMONSTRATION OF COMPLIANCE

The responsibility for review purposes for the measures [09-7C-201](#) to [09-7C-205](#) lies with the lead clinician of the POSCU.

Notes:

The lead clinician of the POSCU would normally be expected to act as the head of service of the POSCU chemotherapy service.

Any given measure is applicable to all levels of POSCU except where stated otherwise.

POSCU level 2 policy for the location of outpatient chemotherapy delivery

09-7C-201

Outpatient IV bolus chemotherapy or day care infusion chemotherapy should only be given in specified room(s) covered by a policy whereby:

- on the sessions the IV chemotherapy is being given, the room(s) should only be used for this purpose or other outpatient or day care clean treatment or procedures.

Note:

Such terms as 'departments', 'units', 'suites', 'areas' and 'facilities' etc, are all difficult to define with precision but they are all made up of a room or rooms.

Compliance: The policy specifying the room(s) agreed between the head of service and the relevant hospital manager.

The reviewers should enquire of the hospital's working practice.

Availability of specific regimens/protocols/emergency

09-7C-202

The areas/wards/rooms identified in measures [09-7C-204](#) to [09-7C-208](#) should have available to them:

- the regimen details for the regimens in use;
- protocol documents and equipment for the management of at least the following emergencies:
 - anaphylactic shock
 - extravasation of cytotoxics
 - cardiac arrest
 - spillage of cytotoxics.

Compliance: The reviewers should inspect the information in those locations.

Area for temporary storage of chemotherapy agents

09-7C-203

The areas/wards/rooms identified in measures [09-7C-204](#) to [09-7C-208](#) should have within them, or adjacent to them, a separate and identified area for the temporary storage of chemotherapy agents which have been dispensed from pharmacy, and for tasks involved in preparation and delivery of treatment.

The storage area should have a lockable fridge and cupboard specifically for the storage of chemotherapy agents.

Note:

MEASURE DETAILS & DEMONSTRATION OF COMPLIANCE

These tasks refer to those which the service decides do not need to be done in a specialised, clean pharmacy preparation unit.

Compliance: The reviewers should view the rooms.

Availability of single rooms for inpatient isolation

09-7C-204 The POSCU should have an agreed number of single rooms (not one room only), to be used for inpatient isolation, each with en-suite toilet and washing facilities.

Compliance: The number agreed by the head of service and the relevant hospital manager.
The reviewers should view the rooms.

Area for paediatric oncology clinic

09-7C-205 The outpatient clinic specified in the 'paediatric oncology clinic' measure [09-7C-209](#) should be held such that it, together with its waiting area, is spatially or temporally separated from all other outpatients clinics.

Compliance: The hospital outpatient department weekly schedule.
If relevant, the reviewers should view the department.

Note:

This measure is designed to reduce the exposure of patients to the risk of cross-infection

DAY CARE/OUTPATIENT TREATMENT FACILITIES (Measures [09-7C-206](#) to [09-7C-210](#))

The day care facilities (this is likely to be a common day care/outpatient facility) should have:

Day care waiting room

09-7C-206 A waiting room exclusive to the use of the patients and carers using the day care facility on the days it is being used as such.

Compliance: The reviewers should enquire as to the hospitals working practice.

Note:

Practices more rigorous than this - i.e. waiting areas permanently exclusive to such patients, obviously also comply

Availability of day care paediatric resuscitation equipment

09-7C-207 Paediatric resuscitation equipment in the room(s) where day care treatment takes place. There should be an equipment check at least weekly.

Compliance: The reviewers should view the equipment and enquire as to the hospital's working practice.

Note:

This measure is not intended to produce a detailed inspection of the contents and type of the equipment.

Day care recovery rooms

09-7C-208 Day care recovery beds - i.e. a ward or part of a ward; or room(s) with day beds, covered by a policy whereby:

- on the sessions that the POSCU's day care facility is being used, the rooms are used only for its patients who are resting after day care treatments or after invasive investigation, or for other outpatients who have had clean day care procedures.

Note:

The above facility is required but it is acceptable practice for children to recover initially in a general recovery area before transferring to a children's recovery area.

Compliance: The policy, specifying the rooms, agreed by the head of service and the relevant hospital manager.

The reviewers should view the facilities.

MEASURE DETAILS & DEMONSTRATION OF COMPLIANCE

Paediatric oncology clinic

09-7C-209 There should be a regular (scheduled) outpatient clinic at a host hospital of the POSCU which:

- i) should be identified in the hospital's outpatient department clinic list or timetable as a clinic for patients under the care of the POSCU;
- ii) should have a facility for physically separating oncology patients from potentially infectious patients;
- iii) should be identified, together with a contact point for referral, in the initial referral protocol specified in measure [09-7A-113](#);
- iv) should have the lead clinician of the POSCU as a member of its medical staffing.

Compliance: Hospital outpatient department timetable or clinic list.
For point (ii), the reviewers should enquire as to the hospital's working practice.
The relevant extract from the initial referral protocol.
Work plan of the lead clinician of the POSCU.

The oncology ward

Note:

The term oncology ward is used for peer review purposes only to denote the ward which is defined in the measure below. The local name for such a ward or any other specialties which may occupy this ward is not subject to review.

The oncology ward

09-7C-210 There should be a written policy whereby paediatric oncology patients should be cared for on a single named children's ward where this is agreed as part of the ward's regular activity and to which patients are admitted in preference to other wards.

Notes:

- Where there is only one ward for children in the host hospital of the POSCU this is automatically compliant.
- Where there is a ward reserved exclusively for paediatric oncology patients this is automatically compliant.

Compliance: The policy, naming the ward, agreed between the lead clinician of the POSCU and the relevant hospital manager. The reviewers should enquire of the hospital's practice.

NURSE NUMBERS AND TRAINING LEVELS (Measures [09-7C-211](#) to [09-7C-212](#))

Introductory Note

It is an underlying assumption of these measures that where a 'nurse' is referred to without any further specification this refers to a registered sick children's nurse, or registered nurse (child). Any other qualifications referred to are in addition to these initial qualifications.

POSCU level 2 foundation internal training for oncology ward nurses

09-7C-211 A minimum of two, day and night, nurses working on the **oncology ward** should be trained at least to the 'foundation internal' training level as specified in the introduction.

Compliance: The number (head count) on the oncology ward; a current duty roster for the ward.
The training confirmation of the relevant nurses.

POSCU level 2 training for day care nurses

09-7C-212 A minimum of two nurses on duty during each shift of each working day that the **day care facility** is open for chemotherapy should be trained at least to the 'full internal' training level as specified in the introduction.

- on days that the facility is open but **not** for chemotherapy, there should be a minimum of two nurses during each shift trained at least to the 'foundation internal' level as specified in the introduction.

MEASURE DETAILS & DEMONSTRATION OF COMPLIANCE

Compliance: The number (head count) and the training certification of the relevant nurses.
A current duty roster for the day care facility.

MEDICAL STAFFING (Measures [09-7C-213](#) to [09-7C-222](#))

Note:

The role of lead clinician of the POSCU should be undertaken by the lead clinician of the POSCU MDT as is dealt with in measure [09-7C-401](#).

Deputy lead clinician and responsibilities

09-7C-213

There should be a named deputy lead clinician for the POSCU.
They should agree the responsibilities of the role with the lead clinician of the POSCU.

Note:

The deputy need not be a consultant, but if not they should be a non-consultant career-grade post.

Compliance: The named deputy and the responsibilities of the role, agreed by the lead clinician of the POSCU.

Workload assessment of lead clinicians

09-7C-214

A workload assessment should be carried out for the lead clinician and deputy lead clinician, based on a workload diary for each clinician over a specified six month period.

Compliance: The workload assessment.

Specified PAs for lead clinician and deputy lead clinician

09-7C-215

The lead clinician and deputy lead clinician should agree with their clinical director (or equivalent) in the host trust, an estimate of the number of DCC PAs and supporting PAs for each clinician which are needed for the work of the POSCUs.

The estimated number of PAs should be included in the job plans of the lead clinician and deputy lead clinician.

Note:

If the lead clinician or deputy lead is the clinical director the estimate should be agreed with the medical director of the host trust.

Compliance: The number of PAs agreed by the clinical director.
The job plans.

Resident medical cover rota

09-7C-216

Applicable to level 2 and 3 POSCUs and only those level 1 POSCUs which have been agreed as accepting patients with neutropenic sepsis.

- there should be a resident cover rota for the POSCU whereby there is 24/7 cover, resident on-call from medical staff of ST3 minimum level of seniority.

Notes:

- Non-consultant specialist career grades may also take part.
- The ST3s and career grades may specialise in paediatric oncology or general paediatrics or other branches of acute paediatrics.

Compliance: An example of a rota showing named doctors agreed by the lead clinician of the POSCU.

POSCU role in CCN medical cover

09-7C-217

The POSCU should agree its role in the CCN medical cover arrangements (measure [09-7A-125](#)).

Compliance: The cover arrangements agreed by the lead clinician of the POSCU.

Note:

The CCNCG for compliance with their relevant measure should produce the arrangements and the POSCU, for compliance with this measure, should agree to abide by them.

MEASURE DETAILS & DEMONSTRATION OF COMPLIANCE

CCLG membership of lead clinician

09-7C-218 The POSCU lead clinician should be a member or associate member of the children's cancer and leukaemia group (CCLG).

Compliance: Written proof of membership.

Protocol co-ordinator

09-7C-219 There should be a named person at the POSCU who should be a core member of a POSCU MDT, who has the responsibility for receiving, acknowledging, archiving and distributing CCN protocols and protocol amendments.
They should agree a list of responsibilities of the role with the lead clinician of the POSCU.

Note:

The person need not be clinical. The role need not necessarily be full time, but should have specified time in their job description.

Compliance: The named person agreed by the lead clinician of the POSCU.
The list of responsibilities agreed by the lead clinician of the POSCU.
The specified time

Proposals for service development plan

09-7C-220 The POSCU's proposals for the service delivery plan for the three years subsequent to the publication of these measures should be incorporated into the 'proposals for the service development' of the relevant locality group in their host cancer network.
Their proposals should be sent to the CCNCG for prioritisation and used towards the CCN's service delivery plan.

Compliance: The locality group's proposals for local development and a written communication by the locality group to the CCNCG; all agreed by the chair of the locality group and the lead clinician.

Cancer services directory of the POSCU locality

09-7C-221 The following should be included in the cancer services directory of the POSCU's locality:

- i) the core members of the POSCU MDT and the contact point for the team;
- ii) the location of the POSCU chemotherapy service and contact points for the 24-hours chemotherapy advice service;
- iii) the contact point for the paediatric oncology palliative care service and 24-hour palliative care advice;
- iv) the location of and contact points for the paediatric radiotherapy service;
(note: this will normally be in the locality of the PTC, but there may be a palliative paediatric radiotherapy service in the locality of the POSCU);
- v) the location and core members of the PTC diagnosis and treatment MDT and the contact point for the team;
- vi) the location and core members of the TYA MDT and the contact point for the team;
- vii) the patients' and carers' support groups which the CCNCG endorses with local contact points;
- viii) the psychological support and bereavement support services

Notes:

- This directory may include additional information on paediatric oncology services.
- A network directory may be developed - including PTC and POSCU services in a single combined directory.
- Any trust providing chemotherapy to children must also be assessed against existing chemo measures.

Compliance: The directory agreed by the chair of the locality group.

MEASURE DETAILS & DEMONSTRATION OF COMPLIANCE

24-hour telephone advice service

09-7C-222

The POSCU should agree the minimum service specification with the PTC and should specify in particular (see measure [09-7B-128](#)):

- the contact number(s) they will use;
- the specified staff they will provide and for which parts of a 24-hour rota;
- their locally applicable policy for instructions to patients and carers.

Notes:

- *The POSCU may agree to provide a 24-hour rota exclusively for their own service, or may contribute staff to a service shared with other parts of the CCN. This is for agreement with the PTC.*

The POSCU may agree to the service being provided entirely by the PTC.

Compliance: The written specification agreed by the chair of the CCNCG and the lead clinician of the POSCU with the local features as specified above.

The reviewers should enquire whether the POSCU is providing its agreed contribution to the rota.

Note:

The CCNCG, for its compliance with its relevant measure, should produce the specification and the POSCU, for its compliance with this measure, should agree with it and provide its contribution.

THE POSCU CHEMOTHERAPY MEASURES (Measures [09-7C-223](#) to [09-7C-240](#))

Introduction

Other than surgical treatment and radiotherapy, the definitive treatment of children with malignancy for the purpose of peer review is considered to be carried out by the specialty of paediatric oncology. Within this group there is usually subspecialisation into paediatric solid tumour treatment specialists and specialists in the treatment of paediatric haematological malignancy. The term paediatric haematology is, for the purpose of peer review, taken to mean the specialty which treats children with non-malignant haematological disorders and is outside the scope of the measures and peer review.

The treatment of children with radiotherapy is carried out by the clinical oncology specialty, usually by specialists who also have an adult radiotherapy practice.

The chemotherapy service of the POSCU is reviewed under measures [09-7C-223](#) to [09-7C-240](#). All the chemotherapy facilities and staff and chemotherapy related activities which come under the measures are reviewed as one entity for the POSCU. This entity is what is referred to as 'the chemotherapy service'. For example, there should be a single head of service for all chemotherapy for the POSCU.

The chemotherapy measures refer to 'the chemotherapy service'. Prior to these measure and the peer review of children's cancer services, it may not have been conventional for the staff involved to consider themselves as part of such a defined entity as could be identified by a label like 'the chemotherapy service' - prescribing and administering chemotherapy were just part of the job as a whole.

However, if definite quality measures are going to be applied in reality to the structures and processes involved in children's chemotherapy, then the compliance with these measures has to be verified 'on the ground' in relation to concrete existing practices. Thus a peer review visit has to relate to a recognised, declared set of people and facilities, with some boundary between them and whoever is going to be reviewed by a different visit. Also this allows for consistency of practice - for example, a set of practice guidelines are understood to apply across the whole of the defined service, which prevents groups of staff disagreeing over practice and asking to be peer reviewed separately.

In the case of children's chemotherapy, the service is also defined by the age boundary, with the provisions regarding flexibility as stated in the introduction to the children's cancer measures.

In common with the rest of the Manual for Cancer Services, the responsibility for peer review purposes of every measure is attributed to some named person or other. For chemotherapy this person is termed the 'head of service', which again may be a somewhat new role for some organisations. The same considerations apply to an oncology pharmacy service and the lead pharmacist.

Future revisions of the children's cancer chemotherapy measures may need to take into account any general changes in national guidance on chemotherapy which follow such reviews as the NCEPOD enquiry into chemotherapy and the reports of the NCAG.

Nomenclature.

The term '**chemotherapy**' refers to the use of those cytotoxic agents commonly understood and accepted as being covered by this term. The inclusion of certain other agents which may or may not be understood to fall clearly into this group is permissible - for example biological therapies. The exact extent of the drugs to be included under the remit of the measures is a matter for local discretion unless otherwise stated in the

MEASURE DETAILS & DEMONSTRATION OF COMPLIANCE

measures themselves. It will largely be manifested by which regimens and which supportive drugs are named in the CCN list and local lists of regimens.

For this set of measures, **systemic, intravenous, intramuscular, oral and subcutaneous** chemotherapy is included. Topical and intracavity chemotherapy is not included. The position regarding **intrathecal** chemotherapy is dealt with separately.

In the measures, chemotherapy is referred to as being given over a complete period of treatment known as a **course**, which consists of giving the drugs over a repeated pattern known as a **cycle**. For entirely oral chemotherapy, a cycle may be defined by the length of time in between mandatory reviews. The maximum intended number of cycles and therefore the intended length of the course may be pre-determined or **fixed**, or dependent on various factors and therefore **indeterminate or variable** from the outset. The separate occasions when drugs are given within a cycle are termed **administrations**. These are usually understood to refer to occasions of parenteral administration rather than say daily oral doses, oral treatment being referred to in the conventional way of pharmacological prescriptions.

None of the above terms as used in these measures are intended to have any other meanings or connotations other than those stated. Where a measure is intended to refer to a particular level of professional training or seniority, it will be stated. If it is local practice to use different terms, meanings or connotations this is not a matter for the measures or peer review.

The responsibility for review purposes for measures [09-7C-223](#) to [09-7C-240](#) lies with the head of service.

The head of service list of responsibilities

09-7C-223 The head of service should agree a list of responsibilities for the role with the lead cancer clinician of the trust involved in the chemotherapy service and the head of service's line manager.

Note:

The head of service would normally be expected to be the lead clinician of the POSCU - see [09-7A-105](#).

Compliance: The list of responsibilities agreed by the lead cancer clinician and the line manager.

POSCU list of acceptable regimens

09-7C-224 The head of service should agree the list of acceptable regimens for the service with the CCNCG and the network chemotherapy group of the host cancer network of the POSCU. The list should be compatible with the agreed care level of the POSCU and should be updated annually.

The service should agree the list (specified in measure [09-7A-130](#)) of regimens, parts of regimens, routes and settings which identify the permissible practice of nurses who have undergone only the CCN's low risk training programme in chemotherapy administration.

Notes:

- *For compliance with measure [09-7A-130](#) the CCNCG should agree the list of regimens for the CCN, across the PTC and all POSCUs and levels; and the POSCU, for compliance with this measure should agree its service's list compatible with the list for the CCN.*
- *For level 2 and 3 POSCUs, the list should specify which regimens should be allowed as day care regimens which can be given at the POSCU.*
- *For level 3 POSCUs, the list should specify which regimens should be allowed as inpatient regimens which can be given at the POSCU.*

Compliance: The POSCU list (or updated, see below) for the year prior to the review visit or completed self assessment, as hard copy or on a computerised prescribing system agreed by the chair of the CCNCG and the head of service.

For POSCUs established for two or more years since the publication of these measures the lists are needed from the first year, then the agreed updates for each subsequent complete year up to the peer review visit or completed self assessment.

Policy for preventing regular use of regimens not on the agreed list

09-7C-225 The head of service should agree a written policy with the CCNCG for preventing regular use of regimens not on the accepted list. The policy should state:

- the exceptional circumstances under which such a regimen could be used;
- the procedure which is then required to authorise it.

MEASURE DETAILS & DEMONSTRATION OF COMPLIANCE

Note:

The CCNCG should produce the policy for its compliance with measure [09-7A-131](#) and the POSCU should agree to abide by it for its compliance with this measure.

Compliance: The written policy agreed by the chair of the CCNCG and the head of service.

Record of the use of unlisted regimens

09-7C-226

The chemotherapy service should record, for review by the CCNCG, the instances of the use of a regimen which is not on the agreed list. They should record in each case:

- the regimen used;
- the indication for its use.

Compliance: The record of the use of regimens which are not on the agreed list.

GUIDELINES/PROTOCOLS FOR HOSPITAL STAFF FOR THE PREVENTION AND TREATMENT OF THE COMPLICATIONS OF CHEMOTHERAPY (Measures [09-7C-227](#) to [09-7C-240](#))

Introduction

The term guidelines/protocols is used since some parts may be in the form of general advice (guidelines) and some may be in the form of precise instructions (protocols). They may form part of a wider ranging set of information. There may be different documents for solid tumour oncology than for haemato-oncology or there may be documents common to both. All these options are acceptable providing measures [09-7C-227](#) to [09-7C-240](#) are complied with. They should all be agreed by the head of service.

Guidelines/protocols on pre-chemotherapy investigations

09-7C-227

There should be guidelines/protocols covering laboratory blood tests and other investigational parameters to be fulfilled prior to starting chemotherapy, before a whole course and before individual cycles, covering both generic parameters and those specific to the regimens on the service's agreed list.

Note:

It would be easy to make this measure impossible to comply with because of the open-ended range of possible parameters. Reviewers are required to exercise their discretion to judge whether this issue has been realistically addressed.

Compliance: The written guidelines/protocols agreed by the PTC and POSCU heads of service

General chemotherapy guidelines/protocols

09-7C-228

There should be guidelines/protocols covering the following:

- cytotoxic administration techniques;
- the care of those venous access devices used by the service, including the treatment of line complications;
- the recognition and treatment of neutropenic sepsis;
- the use of blood products;
- the prevention and treatment of cytotoxic-induced emesis;
- the recognition and treatment of cytotoxic extravasation;
- the recognition and treatment of allergic reactions including anaphylaxis;
- the prevention and treatment of stomatitis, other mucositis and diarrhoea.

Note:

Reviewers should check guidelines and protocols are appropriate for children's cancer.

Compliance: The written guidelines/protocols as agreed by PTC and POSCU lead clinicians and heads of service.

Regimen-specific guidelines/protocols

09-7C-229

There should be guidelines/protocols for the treatment and/or prevention of regimen-specific complications not included in the above measure and relevant to the regimens on the services agreed list of regimens.

Note:

MEASURE DETAILS & DEMONSTRATION OF COMPLIANCE

The following are by way of illustration and may not all be applicable:

- IV pre and post-hydration
- folinic acid rescue
- the use of MESNA
- the prevention of serious hypersensitivity reactions.

Compliance: The written guidelines/protocols as agreed by PTC and POSCU heads of service.

Note:

It would be easy to make this measure impossible to comply with because of the open-ended range of possible complications and remedies. The reviewers are required to exercise their discretion to judge whether this issue has been realistically addressed.

RECORDING OF CHEMOTHERAPY TREATMENT (Measures [09-7C-230](#) to [09-7C-232](#))

These measures address, for specified parts of the pathway, the content of the records, not who does the recording or where the records are kept, or any other aspects of the use of records. The same record contents should be available at PTC and POSCU for a given patient who receives parts of their treatment at the PTC and at a POSCU.

Pre-course records

09-7C-230 There should be treatment records for each patient fulfilling the following minimum criteria prior to the start of a **course** of chemotherapy:

- patient identification;
- weight, height, surface area;
- cancer type;
- regimen and doses (including all cytotoxic chemotherapy drugs to be used and elective essential support drugs other than anti-emetics); trial name or number, if applicable;
- route of administration (oral, IV, IV infusion, IM, SC);
- number of cycles intended;
- frequency of cycles and of administrations within a cycle;
- investigations necessary prior to starting the whole course;
- investigations to be performed serially during the course (to detect/monitor both toxicity and response) and their intended frequency;
- number of cycles;
- attendances managed by agreed non-medical staff, for example nurse led attendances;
- site of administration (PTC, POSCU, community).

Compliance: Reviewers should examine examples of patients' chemotherapy records or the computerised prescribing programme.

Pre-cycle records

09-7C-231 There should be treatment records for each patient fulfilling the following minimum criteria, prior to each **cycle**:

- the results of essential serial investigations applicable to that cycle (and prior to an administration within a cycle, if applicable);
- any dose modifications and whether or not they are intended to be permanent;
- any cycle (or administration) delays;

any introduced support drugs not recorded under measure [09-7C-230](#).

Compliance: Reviewers should examine examples of patients' chemotherapy records or computerised prescribing programme.

Post-course records

09-7C-232 There should be treatment records for each patient fulfilling the following minimum criteria **after** the **final cycle** is given in a course:

- whether the course was completed or not;

MEASURE DETAILS & DEMONSTRATION OF COMPLIANCE

- if not completed - the reasons for cessation:
 - toxicity
 - suboptimal response (for non-adjuvant treatment)
 - disease recurrence during adjuvant treatment
 - others, or combination of the above;
- for completed courses of non-adjuvant treatment a reference to the response should be included.

Compliance: Reviewers should examine examples of patients' chemotherapy records, or computerised prescribing programme.

Verification procedure

09-7C-233

There should be a verification procedure, which is carried out before each physical administration of chemotherapy, to ensure that the following aspects are correct:

- patient's identification, as agreed with the patient on that occasion, on the prescription and on all labelled drugs;
- critical test results;
- regimen and individual drug identification;
- diluents and dilution volumes and any hydration;
- that supportive drugs have been given as per prescription;
- administration route and duration;
- cycle number;

the administration as per the schedule within the cycle.

Compliance: The written procedure agreed by the head of service.
Reviewers should enquire of the local practice.

Out of hours chemotherapy policy

09-7C-234

There should be a policy for the chemotherapy service, agreed with the supporting oncology pharmacy service(s) and the relevant hospital manager(s), stating:

- in which, and only which, exceptional circumstances the initiation of an administration of chemotherapy may be allowed outside 'normal working hours';
- the arrangements for administering chemotherapy which then apply.

Notes:

- *The exact definition of 'normal working hours' should be agreed locally as part of the policy.*
- *It is widely accepted and strongly recommended that chemotherapy should, as far as possible, take place during normal working hours. It is more practical, however, from the point of view of a precise review measure, to define and agree the few exceptions to this rule.*

Compliance: The policy agreed by the head of service, the lead pharmacist(s) of the supporting oncology service(s) and the relevant hospital manager(s).

MEASURE DETAILS & DEMONSTRATION OF COMPLIANCE

TRAINING FOR STAFF ADMINISTERING CHEMOTHERAPY (Measures [09-7C-235](#) to [09-7C-240](#))

Introduction

The CCNCG should agree a nurses' training programme in chemotherapy administration using the RCN competencies with special modifications for training for low risk treatments and for medical staff administering chemotherapy.

There should be a named experienced and trained chemotherapy nurse for each chemotherapy service who should be responsible for training and assessing the competencies of staff. Each chemotherapy service should maintain a list of those staff who are competent and authorised to administer chemotherapy. There are exemptions at first for those who are already trained and experienced. (See the introduction to the children's cancer measures).

It takes time to implement this, so the significance of a service's failure to have only authorised staff administering chemotherapy increases with the run up time available to them before the service's peer review. Lack of compliance should be a matter for discussion between the zonal peer review co-ordinating team and the relevant SHA.

The measures in this section should be applied to each chemotherapy service.

Chemotherapy nurse trainer

09-7C-235

There should be a named chemotherapy nurse for the clinical chemotherapy service with responsibility for training in chemotherapy administration.

The nurse should be qualified to 20 credits at first degree level in paediatric oncology including one module or more in chemotherapy administration and:

the nurse should be currently administering chemotherapy for part of the time, with a minimum of two years previous experience in chemotherapy administration.

The named nurse trainer in the previous measure should:

- have an agreed list of responsibilities which should include:
 - i) choosing nurses who are initially judged able to act as assessors of competence in chemotherapy administration.
Notes:
This responsibility applies only to the first round of peer review against these measures. Once the CCN training programme is established and reviewed it is intended that assessors appointed subsequently would be qualified according to these measures.
 - ii) ensuring that staff administering chemotherapy in the service are trained and assessed for competence according to the RCN standards specified in the introduction or have met the exemption requirements as specified in the introduction;
 - iii) assessing the competence by APEL of nurses trained by other systems to be assessors or authorised administrators of chemotherapy.

- have an agreed minimum time allowed for those responsibilities in their weekly timetable.

Notes:

- *The named nurse may have had two years' experience of chemotherapy administration partially or wholly in another clinical chemotherapy service of the CCN or (with the CCNCG chair's agreement) in another CCN.*
- *The service under review may name more than one nurse trainer, or may share a trainer with other POSCUs and/or the PTC or training could be provided entirely by the PTC. In the latter case, measure [09-7B-146](#) would have the same compliance evidence as the PTC.*

Compliance: The named nurse agreed by the head of service of the chemotherapy service under review.

The confirmation of completion of study.

The start date in chemotherapy administration.

The list of responsibilities and the portion of time agreed by the head of service.

MEASURE DETAILS & DEMONSTRATION OF COMPLIANCE

List of staff authorised to give chemotherapy (nursing)

09-7C-236 The service should maintain a list of named nursing staff, who have been assessed as competent to administer chemotherapy unsupervised, having met the RCN standards specified in the introduction. The list should separately identify those having received low risk training as competent to administer the selected treatments identified in measure [09-7A-136](#).

Note:

See the measure below for inclusion of medical staff on the list.

Compliance: The list of authorised staff agreed by the head of service.
The reviewers should enquire of the working practices of the service in relation to conditions allowing inclusion on the list.

Administration authorisation policy

09-7C-237 The service should agree a policy to the effect that chemotherapy administration staff who are not authorised on the list as defined in measure [09-7C-236](#) may administer chemotherapy only as part of their training and assessment and in the presence of authorised staff.

Compliance: The policy agreed by the head of service. The reviewers should enquire as to the working practices of the department.

Provision of training

09-7C-238 The service should agree to provide the CCN's agreed training programme for its staff, including the agreed part of the programme for medical staff and the low risk training programme.

Compliance: The programme summary agreed by the chair of the CCNCG and the head of service.

List of staff authorised to give chemotherapy (medical)

09-7C-239 There should be a list for the chemotherapy service of medical staff authorised to administer chemotherapy. The service should include the following, and only the following, medical staff on the list:

- those who have been trained and reviewed according to the CCN's agreed programme for medical staff;
- those who have received training according to the previous Manual of Cancer Services Measures (2004);
- those in post administering chemotherapy for two or more years prior to the publication of these measures.

Note:

The service may wish to offer training to the latter category of staff and may wish to make this a pre-condition for their inclusion on the list.

Compliance: The list agreed by the head of service.
The reviewers should enquire of the working practice of the service in relation to conditions allowing inclusion on the list.

Prescribing policy

09-7C-240 The service should agree a prescribing policy to the effect that:

- the decision to treat with a course of chemotherapy and the choice of a particular regimen should only be taken by a consultant paediatric oncologist;
- the prescribing of the first cycle of a course of that previously chosen regimen should be done by consultant paediatric oncologist or specialist NCCG in paediatric oncology or specialist trainee at SP3 level or above.

The policy should be distributed to consultants using the service, medical staff working in their firms or treating their patients oncologically, lead pharmacist(s) and lead nurse(s) associated with the service.

MEASURE DETAILS & DEMONSTRATION OF COMPLIANCE

Compliance: The policy agreed by the head of service.
The reviewers should enquire as to the distribution process.

Notes:
Parts of the compliance evidence may be provided by the security password system of a computerised prescribing system.
Minor short falls in the completeness of the distribution should not preclude compliance with this measure.
The service may agree a more restrictive policy to that specified, or may agree a policy covering the prescribing of cycles subsequent to the first cycle. This is not subject to review.

POSCU ONCOLOGY PHARMACY SERVICES (Measures [09-7C-241](#) to [09-7C-250](#))

Introduction

The clinical chemotherapy service in the PTC or in a POSCU may receive its pharmacy support from a pharmacy which has previously been reviewed as part of the peer review of 'adult' cancer services. If, at such a previous review, there was compliance with the measures regarding preparation facilities and COSHH, they will be regarded as compliant for the review of children's cancer services provided it is within the time frames stated in those measures.

The remaining oncology pharmacy measures should be applied specifically and separately with regards to the children's service.

The responsibility for review purposes for these measures lies with the lead pharmacist.

List of responsibilities for the lead pharmacist

09-7C-241 The lead pharmacist should agree a list of responsibilities for the role with the lead cancer clinician(s) of the trust(s) involved in the service and the lead pharmacist's line manager.

Note:

See the notes below for the case where the lead pharmacist is the only designated pharmacist for the service.

Compliance: The list of responsibilities agreed by the lead cancer clinician(s) and the line manager.

DESIGNATED PHARMACISTS (Measures [09-7C-242](#) to [09-7C-246](#))

Introduction

The duties identified in measures [09-7C-243](#) and [09-7C-244](#) may be divided between more than one designated pharmacist. These need not be their only duties. The duties in measure [09-7C-245](#) should be assigned to a single designated pharmacist. Where the oncology pharmacy service under review has only one pharmacist, they should take the role of designated pharmacist as well as lead pharmacist, and should have all the duties of measures [09-7C-243](#) to [09-7C-245](#) in their list of responsibilities.

Designated pharmacists for the service

09-7C-242 There should be one or more named pharmacists for the service whose role is defined by the duties described in measure [09-7C-243](#) below. For review purposes these pharmacists are termed 'designated pharmacists'.

Note:

The role of designated oncology pharmacist need not occupy the whole of a pharmacist's duties.

Compliance: The named designated pharmacist(s) agreed by the lead pharmacist.

List of responsibilities for the designated pharmacist

09-7C-243 The following duties should be included in the list of responsibilities of a designated pharmacist agreed by the lead pharmacist and the relevant line manager for the children's chemotherapy services declared as being supported by the pharmacy service under review:

- liaison with PTC pharmacist;
- overall responsibility for oncology services to the named wards/areas/outpatient facilities used exclusively or preferentially for chemotherapy and clean procedures;

MEASURE DETAILS & DEMONSTRATION OF COMPLIANCE

- overall responsibility for oncology services to the outpatient services on the days they are used for chemotherapy;
- overall responsibility for cytotoxic chemotherapy.

Compliance: The list of responsibilities of the relevant named designated pharmacist(s) agreed by the lead pharmacist and the relevant line manager.

Responsibility for the preparation facilities

09-7C-244 The following duty should be included in the list of responsibilities of a single designated pharmacist:

- overall responsibility for the clean chemotherapy preparation facilities of the pharmacy service.

Note:

This could instead be on the list of responsibilities of a designated pharmacist of an adult oncology pharmacy service.

Compliance: The list of responsibilities of the relevant named designated pharmacist agreed by the lead pharmacist and the relevant line manager.

Pharmaceutical responsibility for chemotherapy related research

09-7C-245 The following duty should be included in the list of responsibilities of a designated pharmacist:

- liaison over pharmaceutical matters with investigators carrying out clinical trials and/or other clinical research involving the drug treatment of malignant diseases.

Note:

These are investigators working in the children's chemotherapy services supported by the pharmacy service under review.

Compliance: The list of responsibilities of the relevant named designated pharmacist(s) agreed by the lead pharmacist and the relevant line manager.

Pharmacy department organisational chart

09-7C-246 The managerial relationship of the lead pharmacist and, if applicable, the designated pharmacists to the rest of the pharmacy department of the hospital hosting the oncology pharmacy service, should be defined by an organisational chart.

Note:

When a specialist hospital has a pharmacy dealing entirely in oncology this measure should be discussed specifically with reviewers.

Compliance: The organisational chart agreed by the lead pharmacist and the head of the hospital pharmacy department.

PREPARATION FACILITIES (Measures [09-7C-247](#) and [09-7C-250](#))

Introduction to preparation facilities and COSHH

The POSCU chemotherapy service may receive its pharmacy support from a pharmacy which has previously been reviewed as part of a peer review of 'adult' cancer services. The evidence from this, provided for compliance with the measures regarding preparation facilities and COSHH, may serve as evidence for this current review if it is within the allowable timeframes. The remaining oncology pharmacy measures in this section should be applied separately and specifically with regards to the children's cancer chemotherapy service.

External pharmacy audit

09-7C-247 The oncology pharmacy service should have been independently audited for at least the clean preparation of compounds and the preparation of chemotherapy and should have agreed to abide by its findings.

The audit should be conducted as follows:

- licensed units - Medicines and Healthcare Products Regulatory Agency inspection

MEASURE DETAILS & DEMONSTRATION OF COMPLIANCE

- within two years prior to the peer review visit or completed self assessment;
- unlicensed units - an external audit by the Regional Quality Assurance Pharmacist within eighteen months prior to the peer review visit or completed self assessment.

Compliance: The results of the inspection or external audit agreed by the lead pharmacist.

Outcome of the external pharmacy audit

09-7C-248

If the inspection/audit identified in the previous measures requires any matters to be dealt with there should be remedial actions agreed for this. Any resulting proposals for investment should have been presented to the head(s) of the pharmacy department(s) of the host hospital(s) and to the relevant locality group.

Compliance: The remedial actions agreed by the lead pharmacist.
The reviewers should enquire if there were any investment proposals and if they have been presented to the head(s) of pharmacy and the locality groups.

COSHH service review

09-7C-249

The lead pharmacist and an authorised COSHH advisor should have met to review the service against the current COSHH regulations. Any recommendations and/or results of the review should have been made known to the lead manager responsible for risk management in the host NHS trust.

Compliance: The minutes of the meeting and a written submission to the trust risk manager, both agreed by the head of service and having taken plan within the year preceding the peer review visit or completed self assessment.

Prescriptions checked and authorised by a pharmacist

09-7C-250

All cytotoxic chemotherapy prescriptions should be checked and authorised by a pharmacist.

Compliance: Reviewers should spot check prescriptions and/or examine the relevant computerised prescribing software security system.

POSCU radiotherapy

The responsibility for review purposes for the radiotherapy measure lies with the head of service of the radiotherapy department.

POSCU radiotherapy

09-7C-251

The department's techniques and dose/fraction schedules for its children's radiotherapy treatments should be agreed between a consultant clinical oncologist core member of the PTC diagnostic and treatment MDT and the head of service of the radiotherapy department under review.

Note:

The POSCU-associated radiotherapy department should only be offering palliative radiotherapy treatments.

Compliance: The techniques and schedule agreed by the core MDT member and the head of service.

Note:

If there are subspecialist PTC MDTs for the CCN under review and the clinical oncologist core MDT members vary between the MDTs, the regimens should be agreed by all relevant clinical oncology core members.

TOPIC 09-7C-3 - PAEDIATRIC ONCOLOGY SHARED CARE UNIT (POSCU) LEVEL 3 CORE MEASURES

POSCU LEVEL 3 CORE MEASURES

POSCU Level 3 Services

- Inpatient supportive care including care of children with febrile neutropenia.
- Outpatient supportive care.
- Outpatient follow up.
- Outpatient oral chemotherapy.
- Outpatient IV bolus chemotherapy.
- Day care infusional chemotherapy.
- Inpatient 24-hour chemotherapy.
- An intrathecal chemotherapy service in a POSCU, is an option for level 3 (only) providing the following are fulfilled:
 - 1) compliance with HSC 2003-010, as verified by a satisfactory peer review against the ITC measures (Manual for Cancer Services 2004, section 3C-3, or any measures which supersede it);
 - 2) paediatric anaesthetic service on site;
 - 3) agreement by CCNCG.

Level 3 exclusions i.e. Services which should only be offered in a PTC

- 1) Final diagnosis and determination of treatment plan.
- 2) Chemotherapy regimens or other procedures which would be rendered unacceptably hazardous or have their effectiveness reduced by reason of the limits of infrastructure or experience available at any of the POSCUs. These regimens and / or procedures should be specified at any one time for the CCN, by the CCNCG.
- 3) Stem cell transplantation.
- 4) Recruitment to, and co-ordination of, phase I, II and III clinical trials.
- 5) Radical radiotherapy.

MEASURE DETAILS & DEMONSTRATION OF COMPLIANCE

The responsibility for review purposes for the measures [09-7C-301](#) to [09-7C-306](#) lies with the lead clinician of the POSCU.

Notes:

The lead clinician of the POSCU would normally be expected to act as the head of service of the POSCU chemotherapy service.

Any given measure is applicable to all levels of POSCU except where stated otherwise.

POSCU level 3 policy for the location of inpatient chemotherapy delivery

09-7C-301

There should be a written policy whereby inpatient chemotherapy (where patients stay overnight) should only be given on named wards where it is agreed as part of the ward's regular activity and to which such patients are admitted in preference to other wards.
Notes: Day care chemotherapy may also be given on such wards. Wards with stricter policies than above, for example those reserved exclusively for chemotherapy, are also considered compliant with this measure.

Compliance: The policy, naming the wards, agreed between the head of service and the relevant hospital manager. The reviewers should enquire of the hospital's working practice.

POSCU level 3 policy for the location of outpatient chemotherapy delivery

09-7C-302

When outpatient or day care chemotherapy is being given in wards/areas other than those specified in the above measure, it should only be given in specified room(s) covered by a policy whereby:

- on the sessions that chemotherapy is being given the room(s) should only be used for this purpose or other outpatient/day care clean treatment or procedures.

Notes:

MEASURE DETAILS & DEMONSTRATION OF COMPLIANCE

Such terms as departments, units, suites and facilities, etc are all difficult to define with precision but they are all made up of a room or rooms.

Compliance: The policy, specifying room(s), agreed between the head of service and the relevant hospital manager.
The reviewers should enquire of the hospital's working practice.

Availability of specific regimens/protocols/emergency

09-7C-303 The areas/wards/rooms identified in measures [09-7C-305](#) to [09-7C-309](#) should have available to them:

- the regimen details for the regimens in use;
- protocol documents and equipment for the management of at least the following emergencies:
 - anaphylactic shock
 - extravasation of cytotoxics
 - cardiac arrest
 - spillage of cytotoxics.

Compliance: The reviewers should inspect the information in those locations.

Area for temporary storage of chemotherapy agents

09-7C-304 The areas/wards/rooms identified in measures [09-7C-305](#) to [09-7C-309](#) should have within them, or adjacent to them, a separate and identified area for the temporary storage of chemotherapy agents which have been dispensed from pharmacy, and for tasks involved in preparation and delivery of treatment. The storage area should have a lockable fridge and cupboard specifically for the storage of chemotherapy agents.

Note:

These tasks refer to those which the service decides do not need to be done in a specialised, clean pharmacy preparation unit.

Compliance: The reviewers should view the rooms.

Availability of single rooms for inpatient isolation

09-7C-305 The POSCU should have an agreed number of single rooms (not one room only), to be used for inpatient isolation, each with en-suite toilet and washing facilities.

Compliance: The number agreed by the head of service and the relevant hospital manager.
The reviewers should view the rooms.

Area for paediatric oncology clinic

09-7C-306 The outpatient clinic specified in the 'paediatric oncology clinic' measure [09-7C-310](#) should be held such that it, together with its waiting area, is spatially or temporally separated from all other outpatients clinics.

Compliance: The hospital outpatient department weekly schedule.
If relevant, the reviewers should view the department.

Note:

This measure is designed to reduce the exposure of patients to the risk of cross-infection.

DAY CARE/OUTPATIENT TREATMENT FACILITIES (Measures [09-7C-307](#) to [09-7C-312](#))

The day care facilities (this is likely to be a common day care/outpatient facility) should have:

Day care waiting room

09-7C-307 A waiting room exclusive to the use of the patients and carers using the day care facility on the days it is being used as such.

Compliance: The reviewers should enquire as to the hospital's working practice.

Note:

Practices more rigorous than this - i.e. waiting areas permanently exclusive to such

MEASURE DETAILS & DEMONSTRATION OF COMPLIANCE

patients, obviously also comply.

Availability of day care paediatric resuscitation equipment

09-7C-308 Paediatric resuscitation equipment in the room(s) where day care treatment takes place. There should be an equipment check at least weekly.

Compliance: The reviewers should view the equipment and enquire as to the hospital's working practice.

Note:

This measure is not intended to produce a detailed inspection of the contents and type of the equipment.

Day care recovery rooms

09-7C-309 Day care recovery beds - i.e. a ward or part of a ward; or room(s) with day beds, covered by a policy whereby:

- on the sessions that the POSCU's day care facility is being used, the rooms are used only for its patients who are resting after day care treatments or after invasive investigation, or for other outpatients who have had clean day care procedures.

Note:

The above facility is required but it is acceptable practice for children to recover initially in a general recovery area before transferring to a children's recovery area.

Compliance: The policy, specifying the rooms, agreed by the head of service and the relevant hospital manager.

The reviewers should view the facilities.

Paediatric oncology clinic

09-7C-310 There should be a regular (scheduled) outpatient clinic at a host hospital of the POSCU which:

- i) should be identified in the hospital's outpatient department clinic list or timetable as a clinic for patients under the care of the POSCU;
- ii) should have a facility for physically separating oncology patients from potentially infectious patients;
- iii) should be identified, together with a contact point for referral, in the initial referral protocol specified in measure [09-7A-113](#);
- iv) should have the lead clinician of the POSCU as a member of its medical staffing.

Compliance: Hospital outpatient department timetable or clinic list. For point (ii), the reviewers should enquire as to the hospital's working practice. The relevant extract from the initial referral protocol. Work plan of the lead clinician of the POSCU.

POSCU level 3 visiting paediatric oncologist

09-7C-311 The paediatric oncology clinic staffing should include a consultant paediatric oncologist from the PTC, who should attend the paediatric oncology clinic at a frequency agreed with the lead clinician of the POSCU.

Compliance: Work plan of the relevant oncologist from the PTC agreed by the lead clinician of the POSCU.

The oncology ward

Note:

The term oncology ward is used for peer review purposes only to denote the ward which is defined in the measure below. The local name for such a ward or any other specialties which may occupy this ward is not subject to review.

The oncology ward

09-7C-312 There should be a written policy whereby paediatric oncology patients should be cared for on a single named children's ward where this is agreed as part of the ward's regular activity and to which patients are admitted in preference to other wards.

MEASURE DETAILS & DEMONSTRATION OF COMPLIANCE

Notes:

Where there is only one ward for children in the host hospital of the POSCU this is automatically compliant.

Where there is a ward reserved exclusively for paediatric oncology patients this is automatically compliant.

Compliance: The policy, naming the ward, agreed between the lead clinician of the POSCU and the relevant hospital manager. The reviewers should enquire of the hospital's practice.

NURSE NUMBERS AND TRAINING LEVELS (Measures [09-7C-313](#) to [09-7C-314](#))

Introductory Note

It is an underlying assumption of these measures that where a 'nurse' is referred to without any further specification this refers to a registered sick children's nurse, or registered nurse (child). Any other qualifications referred to are in addition to these initial qualifications.

POSCU level 3 full internal training for oncology ward nurses

09-7C-313 A minimum of two, day and night, nurses working on the **oncology ward** should be trained at least to the 'full internal' training level as specified in the introduction.

Compliance: The number (head count) on the oncology ward; a current duty roster for the ward. The training confirmation of the relevant nurses.

POSCU level 3 training for day care nurses

09-7C-314 A minimum of two nurses on duty during each shift of each working day that the **day care facility** is open for chemotherapy should be trained at least to the 'full internal' training level as specified in the introduction.

On days that the facility is open but **not** for chemotherapy, there should be a minimum of two nurses during each shift trained at least to the 'foundation internal' level as specified in the introduction.

Compliance: The number (head count) and the training certification of the relevant nurses. A current duty roster for the day care facility.

MEDICAL STAFFING (Measures [09-7C-315](#) to [09-7C-324](#))

Note:

The role of lead clinician of the POSCU should be undertaken by the lead clinician of the POSCU MDT as is dealt with in measure [09-7C-401](#).

Deputy lead clinician and responsibilities

09-7C-315 There should be a named deputy lead clinician for the POSCU. They should agree the responsibilities of the role with the lead clinician of the POSCU.

Note:

The deputy need not be a consultant, but if not they should be a non-consultant career-grade post.

Compliance: The named deputy and the responsibilities of the role agreed by the lead clinician of the POSCU.

Workload assessment of lead clinicians

09-7C-316 A workload assessment should be carried out for the lead clinician and deputy lead clinician, based on a workload diary for each clinician over a specified six month period.

Compliance: The workload assessment.

Specified PAs for lead clinician and deputy lead clinician

09-7C-317 The lead clinician and deputy lead clinician should agree with their clinical director (or equivalent) in the host trust, an estimate of the number of DCC PAs and supporting PAs for each clinician which are needed for the work of the POSCUs.

The estimated number of PAs should be included in the job plans of the lead clinician

MEASURE DETAILS & DEMONSTRATION OF COMPLIANCE

and deputy lead clinician.

Note:

If the lead clinician or deputy lead is the clinical director the estimate should be agreed with the medical director of the host trust.

Compliance: The number of PAs agreed by the clinical director.
The job plans.

Resident and medical cover rota

09-7C-318 Applicable to level 2 and 3 POSCUs and only those level 1 POSCUs which have been agreed as accepting patients with neutropenic sepsis.

There should be a resident cover rota for the POSCU whereby there is 24/7 cover, resident on-call from medical staff of ST3 minimum level of seniority.

Notes:

Non-consultant specialist career grades may also take part.

The ST3s and career grades may specialise in paediatric oncology or general paediatrics or other branches of acute paediatrics.

Compliance: An example of a rota showing named doctors agreed by the lead clinician of the POSCU.

POSCU role in CCN medical cover

09-7C-319 The POSCU should agree its role in the CCN medical cover arrangements (measure [09-7A-125](#)).

Compliance: The cover arrangements agreed by the lead clinician of the POSCU.

Note:

The CCNCG for compliance with their relevant measure should produce the arrangements and the POSCU, for compliance with this measure, should agree to abide by them.

CCLG membership of lead clinician

09-7C-320 The POSCU lead clinician should be a member or associate member of the children's cancer and leukaemia group (CCLG).

Compliance: Written proof of membership.

Protocol co-ordinator

09-7C-321 There should be a named person at the POSCU who should be a core member of a POSCU MDT, who has the responsibility for receiving, acknowledging, archiving and distributing CCN protocols and protocol amendments.

They should agree a list of responsibilities of the role with the lead clinician of the POSCU.

Note:

The person need not be clinical. The role need not necessarily be full time, but should have specified time in their job description.

Compliance: The named person agreed by the lead clinician of the POSCU and PTC.
The list of responsibilities agreed by the lead clinician of the POSCU.
The specified time.

Proposals for service development plan

09-7C-322 The POSCU's proposals for the service delivery plan for the three years subsequent to the publication of these measures should be incorporated into the 'proposals for the service development' of the relevant locality group in their host cancer network.

Their proposals should be sent to the CCNCG for prioritisation and used towards the CCN's service delivery plan.

Compliance: The locality group's proposals for local development and a written communication by the locality group to the CCNCG; all agreed by the chair of the locality group and the lead

MEASURE DETAILS & DEMONSTRATION OF COMPLIANCE

clinician.

Cancer services directory of the POSCU locality

09-7C-323 The following should be included in the cancer services directory of the POSCU's locality:

- i) the core members of the POSCU MDT and the contact point for the team;
- ii) the location of the POSCU chemotherapy service and contact points for the 24-hours chemotherapy advice service;
- iii) the contact point for the paediatric oncology palliative care service and 24-hour palliative care advice;
- iv) the location of and contact points for the paediatric radiotherapy service (*note: this will normally be in the locality of the PTC, but there may be a palliative paediatric radiotherapy service in the locality of the POSCU*);
- v) the location and core members of the PTC diagnosis and treatment MDT and the contact point for the team;
- vi) the location and core members of the TYA MDT and the contact point for the team;
- vii) the patient's and carers' support groups which the CCNCG endorses with local contact points;
- viii) the psychological support and bereavement support services.

Notes:

- *This directory may include additional information on paediatric oncology services.*
- *A network directory may be developed including PTC and POSCU services in a single combined directory.*
- *Any trust providing chemotherapy to children must also be assessed against existing chemotherapy measures.*

Compliance: The directory agreed by the chair of the locality group.

24-hour telephone advice service

09-7C-324 The POSCU should agree the minimum service specification with the PTC and should specify in particular (see measure [09-7B-128](#)):

- the contact number(s) they will use;
- the specified staff they will provide and for which parts of a 24-hour rota;
- their locally applicable policy for instructions to patients and carers.

Notes:

- *The POSCU may agree to provide a 24-hour rota exclusively for their own service, or may contribute staff to a service shared with other parts of the CCN. This is for agreement with the PTC.*
- *The POSCU may agree to the service being provided entirely by the PTC.*

Compliance: The written specification agreed by the chair of the CCNCG and the lead clinician of the POSCU with the local features as specified above. The reviewers should enquire whether the POSCU is providing its agreed contribution to the rota.

Note: The CCNCG, for its compliance with its relevant measure, should produce the specification and the POSCU, for its compliance with this measure, should agree with it and provide its contribution.

THE POSCU CHEMOTHERAPY MEASURES (Measures [09-7C-325](#) to [09-7C-336](#))

Introduction

Other than surgical treatment and radiotherapy, the definitive treatment of children with malignancy for the purpose of peer review is considered to be carried out by the specialty of paediatric oncology. Within this group there is usually subspecialisation into paediatric solid tumour treatment specialists and specialists in the treatment of paediatric haematological malignancy. The term paediatric haematology is, for the purpose of peer review, taken to mean the specialty which treats children with non-malignant haematological disorders and is outside the scope of the measures and peer review.

The treatment of children with radiotherapy is carried out by the clinical oncology specialty, usually by

MEASURE DETAILS & DEMONSTRATION OF COMPLIANCE

specialists who also have an adult radiotherapy practice.

The chemotherapy service of the POSCU is reviewed under measures [09-7C-325](#) to [09-7C-336](#). All the chemotherapy facilities and staff and chemotherapy related activities which come under the measures are reviewed as one entity for the POSCU. This entity is what is referred to as 'the chemotherapy service'. For example, there should be a single head of service for all chemotherapy for the POSCU.

The chemotherapy measures refer to 'the chemotherapy service'. Prior to these measure and the peer review of children's cancer services, it may not have been conventional for the staff involved to consider themselves as part of such a defined entity as could be identified by a label like 'the chemotherapy service' - prescribing and administering chemotherapy were just part of the job as a whole.

However, if definite quality measures are going to be applied in reality to the structures and processes involved in children's chemotherapy, then the compliance with these measures has to be verified 'on the ground' in relation to concrete existing practices. Thus a peer review visit has to relate to a recognised, declared set of people and facilities, with some boundary between them and whoever is going to be reviewed by a different visit. Also this allows for consistency of practice - for example, a set of practice guidelines are understood to apply across the whole of the defined service, which prevents groups of staff disagreeing over practice and asking to be peer reviewed separately.

In the case of children's chemotherapy, the service is also defined by the age boundary, with the provisions regarding flexibility as stated in the introduction to the children's cancer measures.

In common with the rest of the Manual for Cancer Services, the responsibility for peer review purposes of every measure is attributed to some named person or other. For chemotherapy this person is termed the 'head of service', which again may be a somewhat new role for some organisations. The same considerations apply to an oncology pharmacy service and the lead pharmacist.

Future revisions of the children's cancer chemotherapy measures may need to take into account any general changes in national guidance on chemotherapy which follow such reviews as the NCEPOD enquiry into chemotherapy and the reports of the NCAG.

Nomenclature.

The term "**chemotherapy**" refers to the use of those cytotoxic agents commonly understood and accepted as being covered by this term. The inclusion of certain other agents which may or may not be understood to fall clearly into this group is permissible - for example biological therapies. The exact extent of the drugs to be included under the remit of the measures is a matter for local discretion unless otherwise stated in the measures themselves. It will largely be manifested by which regimens and which supportive drugs are named in the CCN list and local lists of regimens.

For this set of measures, **systemic, intravenous, intramuscular, oral and subcutaneous** chemotherapy is included. Topical and intracavity chemotherapy is not included. The position regarding **intrathecal** chemotherapy is dealt with separately.

In the measures, chemotherapy is referred to as being given over a complete period of treatment known as a **course**, which consists of giving the drugs over a repeated pattern known as a **cycle**. For entirely oral chemotherapy, a cycle may be defined by the length of time in between mandatory reviews. The maximum intended number of cycles and therefore the intended length of the course may be pre-determined or **fixed**, or dependent on various factors and therefore **indeterminate or variable** from the outset. The separate occasions when drugs are given within a cycle are termed **administrations**. These are usually understood to refer to occasions of parenteral administration rather than say daily oral doses, oral treatment being referred to in the conventional way of pharmacological prescriptions.

None of the above terms as used in these measures are intended to have any other meanings or connotations other than those stated. Where a measure is intended to refer to a particular level of professional training or seniority, it will be stated. If it is local practice to use different terms, meanings or connotations this is not a matter for the measures or peer review.

The responsibility for review purposes for measures [09-7C-325](#) to [09-7C-336](#) lies with the head of service.

The head of service list of responsibilities

09-7C-325

The head of service should agree a list of responsibilities for the role with the lead cancer clinician of the trust involved in the chemotherapy service and the head of service's line manager.

Note: The head of service would normally be expected to be the lead clinician of the POSCU - see [09-7A-105](#).

Compliance: The list of responsibilities agreed by the lead cancer clinician and the line manager.

POSCU list of acceptable regimens

09-7C-326

The head of service should agree the list of acceptable regimens for the service with the CCNCG and the network chemotherapy group of the host cancer network of the POSCU.

MEASURE DETAILS & DEMONSTRATION OF COMPLIANCE

The list should be compatible with the agreed care level of the POSCU and should be updated annually.

The service should agree the list (specified in measure [09-7A-130](#)) of regimens, parts of regimens, routes and settings which identify the permissible practice of nurses who have undergone only the CCN's low risk training programme in chemotherapy administration.

Notes:

- For compliance with measure [09-7A-130](#) the CCNCG should agree the list of regimens for the CCN across the PTC and all POSCUs and levels; and the POSCU, for compliance with this measure, should agree its service's list compatible with the list for the CCN.
- For level 2 and 3 POSCUs, the list should specify which regimens should be allowed as day care regimens which can be given at the POSCU.
- For level 3 POSCUs, the list should specify which regimens should be allowed as inpatient regimens which can be given at the POSCU.

Compliance: The POSCU list (or updated, see below) for the year prior to the review visit or completed self assessment, as hard copy or on a computerised prescribing system agreed by the chair of the CCNCG and the head of service.

For POSCUs established for two or more years since the publication of these measures, the lists are needed from the first year, then the agreed updates for each subsequent complete year up to the peer review visit or completed self assessment.

Policy for preventing regular use of regimens not on the agreed list

09-7C-327 The head of service should agree a written policy with the CCNCG for preventing regular use of regimens not on the accepted list.

The policy should state: the exceptional circumstances under which such a regimen could be used; the procedure which is then required to authorise it.

Note:

The CCNCG should produce the policy for its compliance with measure [09-7A-131](#) and the POSCU should agree to abide by it for its compliance with this measure.

Compliance: The written policy agreed by the chair of the CCNCG and the head of service.

Record of the use of unlisted regimens

09-7C-328 The chemotherapy service should record, for review by the CCNCG, the instances of the use of a regimen which is not on the agreed list. They should record in each case:

- the regimen used;
- the indication for its use.

Compliance: The record of the use of regimens which are not on the agreed list.

GUIDELINES/PROTOCOLS FOR HOSPITAL STAFF FOR THE PREVENTION AND TREATMENT OF THE COMPLICATIONS OF CHEMOTHERAPY (Measures [09-7C-329](#) to [09-7C-334](#))

Introduction

The term guidelines/protocols is used since some parts may be in the form of general advice (guidelines) and some may be in the form of precise instructions (protocols). They may form part of a wider ranging set of information. There may be different documents for solid tumour oncology than for haemato-oncology or there may be documents common to both. All these options are acceptable providing measures [09-7C-329](#) to [09-7C-334](#) are complied with. They should all be agreed by the head of service.

Guidelines/protocols on pre-chemotherapy investigations

09-7C-329 There should be guidelines/protocols covering laboratory blood tests and other investigational parameters to be fulfilled prior to starting chemotherapy, before a whole course and before individual cycles, covering both generic parameters and those specific to the regimens on the service's agreed list.

Note:

It would be easy to make this measure impossible to comply with because of the

MEASURE DETAILS & DEMONSTRATION OF COMPLIANCE

open-ended range of possible parameters.

Reviewers are required to exercise their discretion to judge whether this issue has been realistically addressed.

Compliance: The written guidelines/protocols agreed by the PTC and POSCU heads of service.

General chemotherapy guidelines/protocols

09-7C-330

There should be guidelines/protocols covering the following:

- cytotoxic administration techniques;
- the care of those venous access devices used by the service, including the treatment of line complications;
- the recognition and treatment of neutropenic sepsis;
- the use of blood products;
- the prevention and treatment of cytotoxic-induced emesis;
- the recognition and treatment of cytotoxic extravasation;
- the recognition and treatment of allergic reactions including anaphylaxis;
- the prevention and treatment of stomatitis, other mucositis and diarrhoea.

Note:

Reviewers should check guidelines and protocols are appropriate for children's cancer.

Compliance: The written guidelines/protocols as agreed by PTC and POSCU heads of service.

Regimen-specific guidelines/protocols

09-7C-331

There should be guidelines/protocols for the treatment and/or prevention of regimen-specific complications not included in the above measure and relevant to the regimens on the service's agreed list of regimens.

Note:

- *The following are by way of illustration and may not all be applicable:*
- *IV pre and post-hydration*
- *folinic acid rescue*
- *the use of MESNA*
- *the prevention of serious hypersensitivity reactions.*

Compliance: The written guidelines/protocols as agreed by PTC and POSCU lead clinicians and heads of service.

Note:

It would be easy to make this measure impossible to comply with because of the open-ended range of possible complications and remedies. The reviewers are required to exercise their discretion to judge whether this issue has been realistically addressed.

RECORDING OF CHEMOTHERAPY TREATMENT (Measures [09-7C-332](#) to [09-7C-334](#))

These measures address, for specified parts of the pathway, the content of the records, not who does the recording or where the records are kept, or any other aspects of the use of records. The same record contents should be available at PTC and POSCU, for a given patient who receives parts of their treatment at the PTC and at a POSCU.

Pre-course records

09-7C-332

There should be treatment records for each patient fulfilling the following minimum criteria prior to the start of a **course** of chemotherapy:

- patient identification;
- weight, height, surface area;
- cancer type;
- regimen and doses (including all cytotoxic chemotherapy drugs to be used and elective essential support drugs other than anti-emetics);
- trial name or number, if applicable;
- route of administration (oral, IV, IV infusion, IM, SC);
- number of cycles intended;

MEASURE DETAILS & DEMONSTRATION OF COMPLIANCE

- frequency of cycles and of administrations within a cycle;
- investigations necessary prior to starting the whole course;
- investigations to be performed serially during the course (to detect/monitor both toxicity and response) and their intended frequency;
- number of cycles;
- attendances managed by agreed non-medical staff, for example nurse led attendances;
- site of administration (PTC, POSCU, community).

Compliance: Reviewers should examine examples of patients' chemotherapy records or the computerised prescribing programme.

Pre-cycle records

09-7C-333 There should be treatment records for each patient fulfilling the following minimum criteria prior to each **cycle**:

- the results of essential serial investigations applicable to that cycle (and prior to an administration within a cycle, if applicable);
- any dose modifications and whether or not they are intended to be permanent;
- any cycle (or administration) delays;
- any introduced support drugs not recorded under measure [09-7C-332](#).

Compliance: Reviewers should examine examples of patients' chemotherapy records, or computerised prescribing programme.

Post-course records

09-7C-334 There should be treatment records for each patient fulfilling the following minimum criteria, **after the final cycle** is given in a course:

- whether the course was completed or not;
- if not completed - the reasons for cessation:
 - i) toxicity
 - ii) suboptimal response (for non-adjuvant treatment)
 - iii) disease recurrence during adjuvant treatment
 - iv) others, or combination of the above;
- for completed courses of non-adjuvant treatment a reference to the response should be included.

Compliance: Reviewers should examine examples of patients' chemotherapy records or computerised prescribing programme.

Verification procedure

09-7C-335 There should be a verification procedure, which is carried out before each physical administration of chemotherapy, to ensure that the following aspects are correct:

- patient's identification, as agreed with the patient on that occasion, on the prescription chart and on all labelled drugs;
- critical test results;
- regimen and individual drug identification;
- diluents and dilution volumes and any hydration;
- that supportive drugs have been given as per prescription;
- administration route and duration;
- cycle number;
- the administration as per the schedule within the cycle.

Compliance: The written procedure agreed by the head of service.
Reviewers should enquire of the local practice.

MEASURE DETAILS & DEMONSTRATION OF COMPLIANCE

Out of hours chemotherapy policy

09-7C-336 There should be a policy for the chemotherapy service, agreed with the supporting oncology pharmacy service(s) and the relevant hospital manager(s), stating:

- in which, and only which, exceptional circumstances the initiation of an administration of chemotherapy may be allowed outside "normal working hours";
- the arrangements for administering chemotherapy which then apply.

Notes:

- *The exact definition of "normal working hours" should be agreed locally as part of the policy. It is widely accepted and strongly recommended that chemotherapy should, as far as possible, take place during normal working hours.*
- *It is more practical, however, from the point of view of a precise review measure, to define and agree the few exceptions to this rule.*

Compliance: The policy agreed by the head of service, the lead pharmacist(s) of the supporting oncology service(s) and the relevant hospital manager(s).

TRAINING FOR STAFF ADMINISTERING CHEMOTHERAPY (Measures [09-7C-337](#) to [09-7C-342](#))

Introduction

The CCNCG should agree a nurses' training programme in chemotherapy administration using the RCN competencies with special modifications for training for low risk treatments and for medical staff administering chemotherapy.

There should be a named experienced and trained chemotherapy nurse for each chemotherapy service who should be responsible for training and assessing the competencies of staff. Each chemotherapy service should maintain a list of those staff who are competent and authorised to administer chemotherapy. There are exemptions at first for those who are already trained and experienced. (See the introduction to the children's cancer measures).

It takes time to implement this, so the significance of a service's failure to have only authorised staff administering chemotherapy increases with the run up time available to them before the service's peer review. Lack of compliance should be a matter for discussion between the zonal peer review co-ordinating team and the relevant SHA.

The measures in this section should be applied to each chemotherapy service.

Chemotherapy nurse trainer

09-7C-337 There should be a named chemotherapy nurse for the clinical chemotherapy service with responsibility for training in chemotherapy administration.

The nurse should be qualified to 20 credits at first degree level in paediatric oncology including one module or more in chemotherapy administration and the nurse should be currently administering chemotherapy for part of the time, with a minimum of two years previous experience in chemotherapy administration.

The named nurse trainer in the previous measure should:

- have an agreed list of responsibilities which should include:
 - i) choosing nurses who are initially judged able to act as assessors of competence in chemotherapy administration; notes: this responsibility applies only to the first round of peer review against these measures; once the CCN training programme is established and reviewed, it is intended that assessors appointed subsequently would be qualified according to these measures;
 - ii) ensuring that staff administering chemotherapy in the service are trained and assessed for competence according to the RCN standards specified in the introduction or have met the exemption requirements as specified in the introduction;
 - iii) assessing the competence by APEL of nurses trained by other systems to be assessors or authorised administrators of chemotherapy.
- have an agreed minimum time allowed for those responsibilities in their weekly timetable.

Notes:

- *The named nurse may have had two years experience of chemotherapy*

MEASURE DETAILS & DEMONSTRATION OF COMPLIANCE

administration partially or wholly in another clinical chemotherapy service of the CCN or (with the CCNCG chair's agreement) in another CCN.

- The service under review may name more than one nurse trainer, or may share a trainer with other POSCUs and/or the PTC or training could be provided entirely by the PTC. In the latter case, measure [09-7B-146](#) would have the same compliance evidence as the PTC.

Compliance: The named nurse agreed by the head of service of the chemotherapy service under review.
The confirmation of completion of study.
The start date in chemotherapy administration.
The list of responsibilities and the portion of time agreed by the head of service.

List of staff authorised to give chemotherapy (nursing)

09-7C-338 The service should maintain a list of named nursing staff, who have been assessed as competent to administer chemotherapy unsupervised, having met the RCN standards specified in the introduction. The list should separately identify those having received low risk training as competent to administer the selected treatments identified in measure [09-7A-136](#).

Note:

See the measure below for inclusion of medical staff on the list.

Compliance: The list of authorised staff agreed by the head of service. The reviewers should enquire of the working practices of the service in relation to conditions allowing inclusion on the list.

Administration authorisation policy

09-7C-339 The service should agree a policy to the effect that chemotherapy administration staff who are not authorised on the list as defined in measure [09-7C-338](#) may administer chemotherapy only as part of their training and assessment and in the presence of authorised staff.

Compliance: The policy agreed by the head of service. The reviewers should enquire as to the working practices of the department.

Provision of training

09-7C-340 The service should agree to provide the CCN's agreed training programme for its staff, including the agreed part of the programme for medical staff and the low risk training programme.

Compliance: The programme summary agreed by the chair of the CCNCG and the head of service.

List of staff authorised to give chemotherapy (medical)

09-7C-341 There should be a list for the chemotherapy service of medical staff authorised to administer chemotherapy. The service should include the following, and only the following, medical staff on the list:

- those who have been trained and reviewed according to the CCN's agreed programme for medical staff;
- those who have received training according to the previous Manual of Cancer Services Measures (2004);
- those in post administering chemotherapy for two or more years prior to the publication of these measures.

Note:

The service may wish to offer training to the latter category of staff and may wish to make this a pre-condition for their inclusion on the list.

Compliance: The list agreed by the head of service.
The reviewers should enquire of the working practice of the service in relation to conditions allowing inclusion on the list.

MEASURE DETAILS & DEMONSTRATION OF COMPLIANCE

Prescribing policy

09-7C-342

The service should agree a prescribing policy to the effect that:

- the decision to treat with a course of chemotherapy and the choice of a particular regimen should only be taken by a consultant paediatric oncologist;
- the prescribing of the first cycle of a course of that previously chosen regimen should be done by consultant paediatric oncologist or specialist NCCG in paediatric oncology or specialist trainee at SP3 level or above.

The policy should be distributed to consultants using the service, medical staff working in their firms or treating their patients oncologically, lead pharmacist(s) and lead nurse(s) associated with the service.

Compliance: The policy, agreed by the head of service.

The reviewers should enquire as to the distribution process.

Notes:

Parts of the compliance evidence may be provided by the security password system of a computerised prescribing system.

Minor short falls in the completeness of the distribution should not preclude compliance with this measure.

The service may agree a more restrictive policy to that specified, or may agree a policy covering the prescribing of cycles subsequent to the first cycle. This is not subject to review.

POSCU ONCOLOGY PHARMACY SERVICES (Measures [09-7C-343](#) to [09-7C-352](#))

The clinical chemotherapy service in the PTC or in a POSCU may receive its pharmacy support from a pharmacy which has previously been reviewed as part of the peer review of "adult" cancer services. If, at such a previous review, there was compliance with the measures regarding preparation facilities and COSHH, they will be regarded as compliant for the review of children's cancer services provided it was within the timeframes stated in those measures.

The remaining oncology pharmacy measures should be applied specifically and separately with regards to the children's service.

The responsibility for review purposes for these measures lies with the lead pharmacist.

List of responsibilities for the lead pharmacist

09-7C-343

The lead pharmacist should agree a list of responsibilities for the role with the lead cancer clinician(s) of the trust(s) involved in the service and the lead pharmacist's line manager.

Note:

See the notes below for the case where the lead pharmacist is the only designated pharmacist for the service.

Compliance: The list of responsibilities agreed by the lead cancer clinician(s) and the line manager.

DESIGNATED PHARMACISTS (Measures [09-7C-344](#) to [09-7C-348](#))

Introduction

The duties identified in measures [09-7C-345](#) and [09-7C-346](#) may be divided between more than one designated pharmacist. They need not be their only duties. The duties in measure [09-7C-347](#) should be assigned to a single designated pharmacist. Where the oncology pharmacy service under review has only one pharmacist, they should take the role of designated pharmacist as well as lead pharmacist and should have all the duties of measures [09-7C-345](#) to [09-7C-346](#) in their list of responsibilities.

Designated pharmacists for the service

09-7C-344

There should be one or more named pharmacists for the service whose role is defined by the duties described in measure [09-7C-345](#) below. For review purposes these pharmacists are termed "designated pharmacists".

Note:

The role of designated oncology pharmacist need not occupy the whole of a pharmacist's duties.

MEASURE DETAILS & DEMONSTRATION OF COMPLIANCE

Compliance: The named designated pharmacist(s) agreed by the lead pharmacist.

List of responsibilities for the designated pharmacist

09-7C-345 The following duties should be included in the list of responsibilities of a designated pharmacist agreed by the lead pharmacist and the relevant line manager for the children's chemotherapy services, declared as being supported by the pharmacy service under review:

- liaison with PTC pharmacist;
- overall responsibility for oncology services to the named wards/areas/outpatient facilities used exclusively or preferentially for chemotherapy and clean procedures;
- overall responsibility for oncology services to the outpatient services on the days they are used for chemotherapy;
- overall responsibility for cytotoxic chemotherapy.

Compliance: The list of responsibilities of the relevant named designated pharmacist(s) agreed by the lead pharmacist and the relevant line manager.

Responsibility for the preparation facilities

09-7C-346 The following duty should be included in the list of responsibilities of a single designated pharmacist:

- overall responsibility for the clean chemotherapy preparation facilities of the pharmacy service.

Note:

This could instead be on the list of responsibilities of a designated pharmacist of an adult oncology pharmacy service.

Compliance: The list of responsibilities of the relevant named designated pharmacist agreed by the lead pharmacist and the relevant line manager.

Pharmaceutical responsibility for chemotherapy related research

09-7C-347 The following duty should be included in the list of responsibilities of a designated pharmacist:

- liaison over pharmaceutical matters with investigators carrying out clinical trials and/or other clinical research involving the drug treatment of malignant diseases.

Note:

These are investigators working in the children's chemotherapy services supported by the pharmacy service under review.

Compliance: The list of responsibilities of the relevant named designated pharmacist(s) agreed by the lead pharmacist and the relevant line manager.

Pharmacy department organisational chart

09-7C-348 The managerial relationship of the lead pharmacist and, if applicable, the designated pharmacists to the rest of the pharmacy department of the hospital hosting the oncology pharmacy service, should be defined by an organisational chart.

Note: When a specialist hospital has a pharmacy dealing entirely in oncology this measure should be discussed specifically with reviewers.

Compliance: The organisational chart agreed by the lead pharmacist and the head of the hospital pharmacy department.

MEASURE DETAILS & DEMONSTRATION OF COMPLIANCE

PREPARATION FACILITIES (measures [09-7C-349](#) and [09-7C-352](#))

Introduction to preparation facilities and COSHH

The POSCU chemotherapy service may receive its pharmacy support from a pharmacy which has previously been reviewed as part of a peer review of "adult" cancer services. The evidence from this, provided for compliance with the measures regarding preparation facilities and COSHH, may serve as evidence for this current review if it is within the allowable time frames. The remaining oncology pharmacy measures in this section should be applied separately and specifically with regards to the children's cancer chemotherapy service.

External pharmacy audit

09-7C-349 The oncology pharmacy service should have been independently audited for at least the clean preparation of compounds and the preparation of chemotherapy and should have agreed to abide by its findings.

The audit should be conducted as follows:

- licensed units - Medicines and Healthcare Products Regulatory Agency inspection within two years prior to the peer review visit;
- unlicensed units - an external audit by the Regional Quality Assurance Pharmacist within eighteen months prior to the peer review visit.

Compliance: The results of the inspection or external audit agreed by the lead pharmacist.

Outcome of the external pharmacy audit

09-7C-350 If the inspection/audit identified in the previous measures requires any matters to be dealt with there should be remedial actions agreed for this. Any resulting proposals for investment should have been presented to the head(s) of the pharmacy department(s) of the host hospital(s) and to the relevant locality group.

Compliance: The remedial actions agreed by the lead pharmacist.
The reviewers should enquire if there were any investment proposals and if they have been presented to the head(s) of pharmacy and the locality groups.

COSHH service review

09-7C-351 The lead pharmacist and an authorised COSHH advisor should have met to review the service against the current COSHH regulations. Any recommendations and/or results of the review should have been made known to the lead manager responsible for risk management in the host NHS trust.

Compliance: The minutes of the meeting and a written submission to the trust risk manager, both agreed by the head of service and having taken place within the year preceding the peer review visit or completed self assessment.

Prescriptions checked and authorised by a pharmacist

09-7C-352 All cytotoxic chemotherapy prescriptions should be checked and authorised by a pharmacist.

Compliance: Reviewers should spot check prescriptions and/or examine the relevant computerised prescribing software security system.

MEASURE DETAILS & DEMONSTRATION OF COMPLIANCE

POSCU radiotherapy

The responsibility for review purposes for the radiotherapy measure lies with the head of service of the radiotherapy department.

POSCU radiotherapy

09-7C-353

The department's techniques and dose/fraction schedules for its children's radiotherapy treatments should be agreed between a consultant clinical oncologist core member of the PTC diagnostic and treatment MDT and the head of service of the radiotherapy department under review.

Note:

The POSCU-associated radiotherapy department should only be offering palliative radiotherapy treatments.

Compliance: The techniques and schedule agreed by the core MDT member and the head of service.

Note:

If there are subspecialist PTC MDTs for the CCN under review and the clinical oncologist core MDT members vary between the MDTs, the regimens should be agreed by all relevant clinical oncology core members.

TOPIC 09-7C-4 - POSCU, MDT MEASURES

POSCU MULTIDISCIPLINARY TEAM (MDT)

When is a Team a Team and when is it not a Team?

The measures review a variety of aspects of the team, both structure and function, but the key question which underlies all this is who exactly constitutes the MDT from the point of view of the peer review? Which group of people should be put forward for review against these measures and who is it who is held compliant or not compliant?

This is best answered from the patient's point of view. If you were a patient, who would you consider to be your MDT?

Primarily it is that group of people of different health care disciplines, which meets together at a given time (whether physically in one place, or by video or tele-conferencing) to discuss a given patient and who are each able to contribute independently to the diagnostic and treatment decisions about the patient. They constitute that patient's MDT.

The way the MDT meeting itself is organised is left to local discretion such that different professional disciplines may make their contributions at different times, without necessarily being present for the whole meeting in order to prevent wastage of staff time. The key requirement is that each discipline is able to contribute independently to the decisions regarding each relevant patient. The specific situation where a separate "diagnostic" meeting of a particular subset of the MDT membership filters out cases with benign conditions is dealt with where relevant by a specific measure. For some cancer types the IOG had laid down detailed requirements over how the diagnostic process should be incorporated into the MDT system and this has also been translated into the measures where applicable.

MEASURE DETAILS & DEMONSTRATION OF COMPLIANCE

Introduction

The responsibility for review purposes for measure [09-7C-401](#) lies with the cancer lead clinician of the POSCU's host trust (see [topic 1A](#)).

Lead clinician and responsibilities

09-7C-401

There should be a single lead clinician for the POSCU MDT who should then be a core member. The POSCU MDT lead clinician is also taken to be the lead clinician of the POSCU itself.

The lead clinician of the MDT should have agreed the responsibilities of the position with the cancer lead clinician of the host trust.

Note:

These include the responsibilities as lead clinician of the POSCU itself.

Compliance: The named lead clinician for the POSCU MDT agreed by the cancer lead clinician of the host trust and the lead clinical PTC.

The responsibilities agreed by the lead clinician of the MDT and the cancer lead clinician of the host trust.

Note:

See [appendix 1](#) for an illustration of the responsibilities for this role.

MEASURE DETAILS & DEMONSTRATION OF COMPLIANCE

The responsibility for review purposes for the subsequent measures lies with the lead clinician of the MDT.

Core team membership

09-7C-402

The MDT should provide the names of the core team members for the named roles in the team. The core team specific to the POSCU MDT should include:

- lead clinician of the POSCU;
note: see measure [09-7C-401](#), this person should also undertake the role of lead clinician of the POSCU MDT;
- deputy lead clinician of the POSCU;
note: the lead and deputy lead clinicians could cover for each other;
- the POSCU lead cancer nurse;
note: this nurse should be put forward for review against the MDT nurse measures;
- oncology ward nurse;
note: the nurse need not be reviewed against the MDT nurse measures;
- designated pharmacist from the oncology pharmacy service supporting the POSCU chemotherapy service;
- an NHS-employed member of the core team should be nominated as having specific responsibility for users' issues and information for patients and carers;
- MDT co-ordinator/secretary.

Notes:

- *Where a medical speciality is referred to, the core team member should be a consultant. The cover for this member need not be a consultant, but should be at a minimum seniority of staff grade or specialist registrar (ST3).*
- *The co-ordinator/secretary role needs different amounts of time depending on team workload, see [appendix 1](#) for an illustration of the responsibilities of this role.*
- *The co-ordinator and secretarial role may be filled by two different named individuals or the same one. It need not occupy the whole of an individual's job description.*
- *There may be additional core members agreed for the team besides those listed above.*

Compliance: Name of each core team member with their role, agreed by the lead clinician of the MDT.

Note:

The reviewers should record in their assessment each case where the post(s) needed to provide the minimum core membership for a given listed role in the measure is unfilled or non-existent or existing posts cannot provide the service. This does not refer to mere holiday or sickness absence, or less than two thirds attendance and it refers only to the core member roles listed in the measure, not to additional roles that the MDT has decided locally to include as core members. The reviewers should identify the particular missing roles and identify the particular MDT in the report.

MDT MEETINGS (Measures [09-7C-403](#) to [09-7C-405](#))

Frequency of meetings by POSCU level

09-7C-403

The team should hold its meetings as specified for each POSCU level, below, and record core members' attendance.

Level 1 POSCU: the team should meet at least monthly;

Level 2 POSCU: the team should meet at least fortnightly;

Level 3 POSCU: the team should meet weekly.

Compliance: Attendance records of the meetings.

Cover arrangements for core members

09-7C-404

The MDT should agree cover arrangements for each core member.

Notes:

- *This refers to the nominating of staff that should **in general** be expected to provide cover for core members, for example a SpR on a consultant's team or core member*

MEASURE DETAILS & DEMONSTRATION OF COMPLIANCE

of the same discipline providing cover for each other. It does not refer to the member having to provide a person to cover for each and every absence. This aspect is dealt with by the attendance measure below.

- Where a medical speciality is referred to the cover for a core member need not be a consultant, but should be at a minimum seniority of specialist registrar (ST3) or staff grade.
- Lead clinician and deputy lead clinician may cover for each other.
- Nurse specialists may be covered by ward nurses or day care nurses with training compliant with the 'nurse training' measures who may also cover for each other. Pharmacists should be by pharmacists.

Compliance: Written arrangements by the lead clinician of the MDT.

Core members attendance

09-7C-405 Core members or their arranged cover (see measure [09-7C-404](#)) should attend at least two thirds of the number of meetings.

Compliance: Attendance records of the MDT.

Note:

The intention is that core members of the team should be personally committed to it, reflected in their personal attendance at a substantial proportion of meetings not relying instead on their cover arrangements. Reviewers should use their judgement on this matter and should highlight in their report where this commitment is lacking.

OPERATIONAL POLICIES (Measures [09-7C-406](#) to [09-7C-409](#))

Operational policy meeting

09-7C-406 Besides the regular meetings to discuss individual patients the team should meet at least annually to discuss, review, agree and record at least some operational policies.

Compliance: Minutes of at least one meeting agreed by the lead clinician of the MDT to illustrate the recording of at least some operational policies.

Policy for patients to be discussed by the MDT

09-7C-407 There should be an operational policy for the team which specifies which situations in the patient care pathway and/or patient journey should require a review by the POSCU MDT.

Compliance: The policy agreed by the lead clinician.

Key worker policy

09-7C-408 There should be an operational policy whereby a single named key worker for the patient's care at a given time is identified by the MDT for each individual patient and the name and contact number of the current key worker is recorded in the patient's case notes. The responsibility for ensuring that the key worker is identified should be that of the nurse MDT member(s).

The above policy should have been implemented for patients who came under the MDT's care after publication of these measures and who are under their care at the time of the peer review visit or self assessment.

Notes:

- *For information: according to the NICE palliative care guidance a key worker is a person who, with the patient's consent and agreement, takes a key role in co-ordinating the patient's care and promoting continuity, for example ensuring the patient knows who to access for information and advice.*
- *It may be appropriate for a paediatric oncology outreach nurse to be the key worker.*
- *It may be necessary to agree a different key worker for different parts of the patient's pathway. It is intended that at any one time a patient only has one named key worker.*
- *This is not intended to have the same connotation as the key worker in social work. It may be necessary to agree a single key worker across both a cancer site specific*

MEASURE DETAILS & DEMONSTRATION OF COMPLIANCE

MDT and the specialist palliative care MDT for certain patients.

Compliance: The written policy agreed by the lead clinician of the MDT.
Reviewers should spot check some relevant patients' case notes.

Attendance at national communication skills training

09-7C-409 At least those core members of the team who have direct clinical contact with patients should have attended the advanced communication skills training.

Notes:

- *This measure applies only to those disciplines which have direct clinical contact and which are named in the list in the MDT structure measure for core membership.*
- *Also, it applies only with regard to members who are in place i.e. if a team lacks a given core member from that list it should still be counted as compliant with this measure provided those members which are in place comply.*
- *The relevant disciplines include medical, surgical, nursing and allied health professionals.*
- *The reviewers should record which core members of those relevant are non compliant.*

Compliance: Confirmation of attendance at the national advanced communication skills training for each of the relevant core members.

MDT NURSE SPECIALIST MEASURES (Measures [09-7C-410](#) to [09-7C-412](#))

Introduction

Why are there currently 'nursing measures' for MDTs but no similar requirements for other MDT members? The modern change to MDT working has created and then highly developed the specific role of nurse MDT member when its related activities, which in full measure, go to make up the role of cancer nurse specialist. The roles of the medical specialties in the MDT have not been so profoundly influenced or so extensively developed by their MDT membership itself compared to that of the MDT nurse members. The role definitions and training requirements of nurse MDT members are not 'officially' established outside the MDT world in contrast to the well defined medical specialties with their formal national training requirements. Therefore a particularly strong need was perceived for using the measures to define more clearly the role of the nurse member and to set out minimum training requirements for nursing input into MDTs. This is in order to establish these roles more firmly in the NHS infrastructure and to avoid the situation where MDTs can comply with measures by having generalist nurses who 'sit in' on MDT meetings and sign attendance forms, but play no defining role in the team's actual dealing with its patients.

Specialist training for core nurse member

09-7C-410 The MDT should have at least one core nurse member who should have successfully completed a programme of study in paediatric oncology for nurses, which has been accredited for at least 20 credits at first degree level.

Compliance: The confirmation of successful completion of the course.

List of responsibilities for core nurse members

09-7C-411 The MDT should have agreed a list of responsibilities with each of the core nurse members of the team, which includes the following:

- contributing to the multidisciplinary discussion and patient assessment / care planning decision of the team at their regular meetings;
- providing expert nursing advice and support to other health professionals in the nurse's specialist area of practice;
- involvement in clinical audit;
- leading on patient and carers' communication issues and co-ordination of the patient pathway for patients referred to the team - acting as the key worker or responsible for nominating the key worker for the patient's dealings with the team.

Note:

Additional responsibilities to those in this measure and the next measure may be agreed.

MEASURE DETAILS & DEMONSTRATION OF COMPLIANCE

Compliance: The list of responsibilities agreed by the lead clinician of the MDT and the core nurse member(s).

List of additional responsibilities for core nurse members

09-7C-412 The MDT should have agreed a list of responsibilities with at least one of the core nurse members of the team, which in addition to the items listed in measure [09-7C-410](#), includes:

- contributing to the management of the service (see note below);
- utilising research in the nurse's specialist area of practice.

Notes:

- *'Management' in this context does not mean clerical tasks involving the documentation on individual patients i.e. this responsibility does not overlap with the responsibility of the MDT co-ordinator.*
- *A list of responsibilities containing all the elements in this measure and the previous measure would encompass all of the domains of specialist practice required for the role of cancer nurse specialist.*
- *Additional responsibilities to those in this and the previous measure may be agreed.*

Compliance: The list of responsibilities agreed by the lead clinician of the MDT and the relevant core nurse member(s).

FUNCTIONS OF THE TEAM (Measures [09-7C-413](#) to [09-7C-422](#))

PROVIDING PATIENT CENTRED CARE (Measures [09-7C-413](#) to [09-7C-416](#))

Patients' experience exercise

09-7C-413 The MDT should have undertaken or be undertaking an exercise during the previous two years prior to review to obtain feedback on patients' experience of the services offered.

The exercise should at least ascertain whether patients were offered:

- a key worker;
- information about local services including patient self help groups, patient support groups and services (including palliative care), offering psychological, social and spiritual / cultural support as relevant.

Notes:

- *The exercise may consist of a survey, questionnaire, focus group or other method.*
- *There may be additional items in the exercise. It is recommended that other aspects of patient experience are covered.*

Compliance: The results (complete or in progress) of the exercise.

Outcome of patient' experience exercise

09-7C-414 Exercises in [09-7C-413](#) having been completed during the previous two years should have been presented and discussed at an MDT meeting and the team should have implemented at least one action point arising from the exercise.

Compliance: The results of the exercise.
A report of the action taken.

Provision of patient written information

09-7C-415 The MDT should provide written material for patients and carers which includes:

- information specific to the MDT about local provision of the services offering the treatment for children with cancer;
- information about patient support groups and patient self-help groups;
- information about the services (including palliative care) offering psychological, social and spiritual / cultural support, if available;
- information specific to children's cancer about the diseases and their treatment

MEASURE DETAILS & DEMONSTRATION OF COMPLIANCE

options (including names and functions / roles of the team members treating them).

Compliance: The written (visual and audio if used - see note below) material.

Notes:

It is recommended that it is available in languages and formats understandable by patients and / or carers including local ethnic minorities and people with disabilities. This may necessitate the provision of visual and audio material.

Patient care review

09-7C-416 The core MDT at their regular meetings should review individual patient's treatment plans. When a patient's treatment plan is reviewed written evidence that the review has taken place should be recorded.

Compliance: Anonymised examples of the record of a meeting and individual anonymised treatment plans.

Note:

It is recommended that significant events and decisions for individual patients are noted in the record of the MDT meeting as well as in the patient's notes, but the actual content of the meeting is not subject to review only that a written record of each review is kept.

CCN GUIDELINES AND PROTOCOLS (Measures [09-7C-417](#) to [09-7C-422](#))

POSCU initial referral protocol

09-7C-417 The POSCU MDT should agree their role as specified in the initial referral protocol of the CCN.

Compliance: The protocol agreed by the lead clinician of the POSCU MDT.

Note:

The CCNCG, for compliance with their relevant measure, should produce the protocol and the POSCU, for compliance with this measure, should agree to abide by it.

POSCU diagnosis and staging protocol

09-7C-418 The POSCU MDT should agree their role as specified in the diagnosis and staging protocol of the CCN.

Compliance: The protocol agreed by the lead clinician of the POSCU MDT.

Note:

The CCNCG, for compliance with their relevant measure, should produce the protocol and the POSCU, for compliance with this measure, should agree to abide by it.

POSCU clinical management protocols

09-7C-419 The POSCU MDT should agree their role in the clinical management protocols for the CCN.

Compliance: The clinical management protocols agreed by the lead clinician of the POSCU MDT.

Notes:

The CCNCG, for compliance with their relevant measure, should produce the protocols and the POSCU, for compliance with this measure, should agree to abide by them.

The reviewers should report which specific disease protocols the MDT fails to comply with (if any).

POSCU follow up and long term sequelae protocol

09-7C-420 The POSCU MDT should agree their role as specified in the follow up and long term sequelae protocol of the CCN.

Compliance: The protocol agreed by the lead clinician of the POSCU MDT.

Note:

The CCNCG, for compliance with their relevant measure, should produce the protocol and the POSCU, for compliance with this measure, should agree to abide by it.

MEASURE DETAILS & DEMONSTRATION OF COMPLIANCE

POSCU psychosocial assessment guidelines

09-7B-421

The MDT should agree the CCN psychosocial assessment guidelines.

Compliance: The guidelines agreed by the lead clinician of the MDT.

Note:

The CCNCG for compliance with their relevant measure should produce the guidelines and the MDT, for compliance with this measure, should agree to abide by them.

Minimum dataset

09-7C-422

The MDT should be collecting the data for the children's cancer minimum dataset.

Compliance: The reviewers should enquire as to the working practice of the MDT.

TOPIC 09-6A-2 - PCT CHEMOTHERAPY NURSES FOR CHILDREN'S CANCER MEASURES

MEASURE DETAILS & DEMONSTRATION OF COMPLIANCE

The responsibility for review purposes for this measure lies with the cancer clinical lead of the PCT.

PCT chemotherapy nurse for children's cancer

09-6A-201 The PCT should declare whether it employs nurses who administer children's chemotherapy in the community.

Note:

*If it does **not** employ such nurses the rest of this measure is not applicable and the PCT is considered compliant.*

If the PCT employs such nurses, it should:

- agree the CCN's list of 'low risk' regimens routes and settings, which and only which, the PCT's community nurses may administer, (see measure [09-7A-136](#));
- maintain a list of the PCT's nurses who are trained to at least the level of the CCN's 'low risk' internal training who, and only who, are authorised to administer children's chemotherapy in the community unsupervised.

Compliance: The CCN's regimens list agreed by the cancer clinical lead of the PCT.
The list of authorised nurses agreed by the cancer clinical lead of the PCT.
The reviewers should enquire regarding the conditions for inclusion on the authorised 'nurses' list.

TOPIC 09-8A-1 - THE CHILDREN'S CANCER NETWORK COMMISSIONING FUNCTION

Introduction

These measures are based on the principles of World Class Commissioning. No attempt, however, is made to translate all those principles or all commissioning tasks into measures, which would be impractical. Instead, issues have been selected which are thought to be essential for high quality commissioning, but which are not universally practiced, or practiced well enough.

The CYPIOG recommends that: Planning, commissioning and funding for all aspects of care for children and young people with cancer, across the whole healthcare system should be co-ordinated to ensure that there is an appropriate balance of service provision and allocation of resources. (Key recommendations, page 7).

Cancer in children is a specialist condition but they will sometimes be treated in a non specialist setting, for example POSCU. The SCG should ensure that their needs are met throughout the pathway from specialist and non specialist children's services.

These measures address commissioning only for children's cancer services, not for specific teenage and young adult services. Part of the above recommendation is covered not by directly worded measures but as a result of setting up the CCN's infrastructure and in particular the CCNCG, with its specific membership and terms of reference, which is a representative forum for the whole network, both providers and commissioners and allows a final common path for co-ordinated and balanced communication across the CCN and between providers and commissioners. The recommendation is also partly fulfilled by the agreement that children's cancer commissioning will be overseen by one body for a given CCN, the Specialist Commissioning Group (SCG). Each SCG is required to be responsible from the point of view of peer review for commissioning for the CCN whose PTC it designated. The measures in this section cover this process and are measures for the relevant SCG, not the CCNCG.

In some cases a given SCG will have been responsible for designating more than one (probably no more than two), PTCs in its catchment area. Two PTCs mean two separate CCNs (see the introduction to the children's cancer measures). This means that such a SCG will be reviewed separately against the measures in this section, as they relate to the separate CCNs and its performance in the review will be recorded separately on the CQuINS database as relating to each CCN respectively. It should be explicit, where relevant in the compliance evidence, which CCN it refers to.

The responsibility for review purposes for the first measure in this section lies with the CEO of the SCG. The responsibility for subsequent measures lies with the named lead.

MEASURE DETAILS & DEMONSTRATION OF COMPLIANCE

The named lead for commissioning for the CCN

09-8A-101

There should be a named lead from the SCG at director level for commissioning for the CCN, with a list of responsibilities for this role, agreed by the CEO of the SCG.

Note:

Where the SCG is responsible for commissioning for more than one CCN, the role description should make it explicit which CCN it refers to. One commissioning lead may be the lead for more than one CCN, but commissioning for a single, given CCN, should only have one lead.

Compliance:

The named director and the list of responsibilities, agreed by the CEO of the SCG.

Note:

For the rest of these measures, this person will be referred to as the SCG lead.

MEASURE DETAILS & DEMONSTRATION OF COMPLIANCE

THE DELEGATION AGREEMENT

Introduction

The SCG is responsible for coordinating the commissioning responsibilities throughout the pathway.

The delegation agreement

09-8A-102 Where other bodies commission aspects of the pathway, there should be an agreement for each organisation which specifies:

- which organisations are responsible, including cancer networks, individual PCTs, children's networks (i.e. networks dealing with children's services in general), local authorities and practice-based commissioners;
- what each organisation is responsible for, covering where relevant, which patient pathways or parts of pathways, which geographical parts of the network and which part of the commissioning function;
- who is responsible for monitoring the performance and quality and feeding back to the contract lead.

Compliance: The agreement for each organisation; authorised by the SCG lead and a representative of the organisation.

The health needs assessment

09-8A-103 There should be a CCN wide, integrated children's cancer health needs assessment incorporated into the Joint Service Needs Assessment(s) for the catchment area of the CCN.

The service model used to develop the needs assessment should include reference to the National Service Framework for Children and the CYPIOG/Children's Cancer Peer Review Measures.

Compliance: The children's cancer health needs assessment, agreed by the SCG lead and incorporated into the Joint Service Needs Assessment.

Notes:

The compliance documentation is required to be updated every five years, i.e. the health needs assessment may remain unchanged for planning purposes during this time. The SCG may wish to update it with a new assessment for five subsequent years, in the meantime, at its discretion.

If a children's cancer health needs assessment for the CCN has already been agreed prior to the publication of these measures, it is suitable for compliance documentation provided it covered a period of five years

The children's cancer commissioning strategy

09-8A-104 There should be a commissioning strategy which fulfills the following criteria:

- it should encompass the period of the five years which is in line with the specialised service designation process;
- it should specify priorities for service change and investment to meet the requirements of the health needs assessment;
- it should have dated milestones for progressive implementation;
- it should specify the metrics for progress assessment, which should include peer review;
- it should be agreed by stakeholder representatives, including:
 - clinicians involved in the service at PTC and POSCU level;
 - each individual PCT involved, whether as provider or commissioner;
 - network NHS service providers;
 - involved 'adult' cancer networks;
 - involved children's health networks;
 - involved local authorities;
 - involved voluntary and independent sector providers;
 - users and carers.

MEASURE DETAILS & DEMONSTRATION OF COMPLIANCE

Notes:

The stakeholder agreements are to ensure that the priorities have been agreed not only between the different options within children's cancer but between children's cancer and the rest of the children's health agenda, the rest of the cancer agenda and the rest of the health agenda as a whole.

The compliance documentation is required to be updated every five years, i.e. the commissioning strategy may remain unchanged for planning purposes during this time. The SCG may wish to update it with a new assessment for five subsequent years in the meantime, at its discretion

If a children's cancer health needs assessment for the CCN has already been agreed prior to the publication of these measures it is suitable for compliance documentation, provided it covered a period of five years

Compliance: The strategy agreed by the stakeholder representatives as above.

The service specification

09-8A-105

There should be an annual service specification for the CCN which fulfils the following:

- it specifies the patient pathways;
- it refers to the milestones for service change required by the commissioning strategy;
- it has components specific to all providers;
- it is integrated across the CCN as evidenced by its agreement by all identified commissioning bodies.

Compliance: The service specification agreed by the SCG lead and a representative from each delegated commissioning body.

The contracts and SLAs

09-8A-106

The contracts and/or SLAs for children's cancer should make reference to the relevant parts of the service specification and the relevant children's cancer measures.

Compliance: The reviewers should examine a sample of contracts and/or SLAs chosen by the peer review office.

Service monitoring

09-8A-107

The contracts and/or SLAs for children's cancer should state service monitoring criteria which include the following as relevant to the part of the patient pathway and the part of the CCN in question:

- performance against waiting times
- cancer registration
- specified clinical outcome audits
- clinical trial entry rates
- patient reported outcome measures
- providing data required to support designation process.

Compliance: The reviewers should examine a sample of contracts and/or SLAs chosen by the peer review office.

MEASURE DETAILS & DEMONSTRATION OF COMPLIANCE

Discussion of monitoring results

09-8A-108

The results of service monitoring should be taken by the SCG to the CCNCG for discussion at least six monthly.

Remedial actions should be agreed.

Compliance: An extract of the minutes of relevant meetings of the CCNCG from the twelve month period prior to the peer review/self assessment, showing discussions with attendance by an SCG representative.

Remedial action(s) agreed by the SCG lead and the chair of the CCNCG.

Note:

If the SCG lead is the chair of the CCNCG the remedial actions should be agreed by the SCG lead and the lead clinician of the PTC.

Appendix 1

PTC MDT Lead Clinician

- Ensure that objectives of MDT working (as laid out in Manual of Cancer Services) are met:
 - *to ensure that designated specialists work effectively together in teams such that decisions regarding all aspects of diagnosis, treatment and care of individual patients and decisions regarding the team's operational policies are multidisciplinary decisions;*
 - *to ensure that care is given according to recognised guidelines (including guidelines for onward referrals) with appropriate information being collected to inform clinical decision making and to support clinical governance / audit;*
 - *to ensure mechanisms are in place to support entry of eligible patients into clinical trials, subject to patients giving fully informed consent.*
- Overall responsibility for ensuring that MDT meeting and team meet peer review quality measures.
- Ensure attendance levels of core members are maintained, in line with quality measures.
- Ensure that target of 100% of cancer patients discussed at the MDT is met.
- Provide link to NSSG, either by attendance at meetings or by nominating another MDT member to attend.
- Lead on, or nominate lead for service improvement.
- Organise and chair annual meeting examining functioning of team and reviewing operational policies and collate any activities that are required to ensure optimal functioning of the team (for example training for team members).
- Ensure MDT's activities are audited and results documented.
- Ensure that the outcomes of the meeting are clearly recorded and clinically validated and that appropriate data collection is supported.
- Ensure target of communicating MDT outcomes to primary care is met.

PTC - Lead Nurse Children and Young People's Oncology / Haematology

Purpose of the Role

The overriding purpose of the lead nurse role is to provide professional and clinical leadership and support to nursing staff within the Principal Treatment Centre. Post-holders will be responsible for all elements of the nursing services and will also be expected to contribute to the strategic development of the whole service in line with the individual hospital trust and relevant national targets.

Core Elements

The Lead Nurse:

- is an expert in the care of children and young people with cancer;
- has been trained at least according to the external training criteria specified in the introduction to the children's cancer measures;
- advances the development and practice of evidence-based paediatric cancer nursing in the trust, in line with national recommendations and measures where available;
- collaborates with all members of the multidisciplinary team in ensuring the advancement of child and family focused cancer care and support;
- develops and implements communication arrangements with nursing and members of the multidisciplinary team across the network;
- works clinically on a regular basis, (this should be a least 20%) thus demonstrating expert clinical practice, professional competence, authority and credibility;
- works with the trust / network to co-ordinate the nursing elements of preparation for peer review visits or self assessment;
- provides professional advice, leadership and support on haematology / oncology issues to the District General Hospitals (shared care units) within the region;
- is responsible for continuing management and strategic planning of the Regional Children and Young People's haematology / oncology service.

PTC - Lead Therapeutic Radiographer

The following duties should be included in the list of responsibilities of a designated therapeutic radiographer for children and agreed by the relevant line manager for the children's radiotherapy service under review:

- Liaison with PTC clinical oncologist for children.
- Liaison with PTC ward / day ward teams regarding schedules for planning and delivery of radiotherapy treatments.
- Attending MDT meetings as necessary.
- Communication with patients / parents regarding planned radiotherapy treatment schedules.
- Provision of information to children and their families regarding radiotherapy treatment, associated care and possible late effects.
- Liaison with PTC play specialist to provide age-appropriate preparation and support to all children prior to and during planning and delivery of radiotherapy treatment.
- Overall responsibility for advising on age-appropriate facilities, patient / family information and working practices are developed and maintained in the radiotherapy department.
- Provision of education and information to staff regarding radiotherapy for children.
- Maintain professional practice competencies as a therapeutic radiographer.

Responsibilities of the MDT Co-ordinator

- Facilitate and co-ordinate the functions of the multidisciplinary team meetings.
- Ensure the appropriate proportions of patients are discussed at MDTs.
- Help with the introduction and changes to pro-formas used to ensure all patients are discussed, treated appropriately and outcomes are recorded and reviewed. Ensuring patients' diagnoses, investigations and management and treatment plans are completed and added to the patient's notes.
- Managing systems that inform GPs of patient's diagnosis, decisions made at outpatient appointment, etc.
- Working with staff to ensure all patients have a booked first appointment, investigation and procedure and record details of patients coming via a different route.
- Working with key MDT members to identify areas where targets are not achieved, undertake process mapping to identify bottlenecks.
- Undertake demand and capacity studies where appropriate.
- Report changes to MDTs on a monthly basis.
- Data collection and recording of data.
- To manage the systems according to guidelines, monitoring milestones and submitting the required reports in the given format and required times.
- Keep comprehensive diary of all team meetings.
- Record attendance at meetings
- Take minutes at the multidisciplinary meetings, type notes back in the required format and distribute to all concerned.
- The post holder will be expected to be instrumental in the development of databases to capture patient information and report this to the clinicians on a weekly basis.
- Inform lead cancer manager of waiting times for patients when these exceed appropriate targets.
- Ensure lists of patients to be discussed at meetings are prepared and distributed in advance.
- Ensure all correspondence, notes, x-rays results, etc are available for the meetings.
- Ensure action plans for patient care are produced with agreed reviews.
- Assist in capturing cancer data on all patients and assist in the development of systems to complement the cancer audit system.
- Ensure members or their deputies are advised of meetings and any changes of date, venue, etc.

The NHS logo is centered on the page. It consists of the letters 'NHS' in a bold, blue, sans-serif font, set within a white rectangular box. The background of the entire page is a bright blue sky with soft, white clouds. Overlaid on this background are several thick, flowing, abstract lines in shades of light green and light blue, creating a sense of movement and depth.